

ALTRONIC, INC.  
712 TRUMBULL AVE.  
GIRARD, OHIO 44420

**ALTRONIC I IGNITION SYSTEM  
5000 SERIES S/N 5000 & UP**

**IMPORTANT SAFETY NOTICE**

**PROPER INSTALLATION, MAINTENANCE, REPAIR AND OPERATION OF THIS EQUIPMENT IS ESSENTIAL. THE RECOMMENDED PRACTICES CONTAINED HEREIN SHOULD BE FOLLOWED WITHOUT DEVIATION. AN IMPROPERLY INSTALLED OR OPERATING IGNITION SYSTEM COULD CAUSE PERSONAL INJURY TO OPERATORS OR OTHER NEARBY PERSONNEL.**

SECTION	ITEM	PAGE
1.0	SYSTEM DESCRIPTION	3
2.0	PARTS IDENTIFICATION AND SPECIFICATION	4
2.1	Parts List - Altronic I Unit	4-5
2.2	Bearing Identification	5
2.3	Unit Specifications	6
3.0	PERFORMANCE AND TEST SPECIFICATIONS	7
3.1	Bench Test - Altronic I	7
3.2	Stator - Altronic I	7
3.3	Electronic Box - Altronic I	8
3.4	Pick-up Coil - Altronic I	8
3.5	Bench Test - Altronic I-6	9
3.6	Stator - Altronic I-6	9
3.7	Electronic Box - Altronic I-6	10
3.8	Pick-up Coil - Altronic I-6	10
4.0	SERVICE - ALTRONIC I UNIT	11
4.1	Disassembly - Alternator	11
4.2	Disassembly - Front Housing Assembly	11
4.3	Reassembly - Front Housing Assembly	11
4.4	Reassembly - Alternator	12
4.5	Reassembly - Electronic Box to Alternator	12
5.0	SERVICE-ASSEMBLY TOOLS	12
6.0	OPERATIONAL TEST	12

## 1.0 ALTRONIC I IGNITION SYSTEM - DESCRIPTION

The Altronic I 1-cylinder ignition system is depicted below; the principle of operation is the same for all Altronic I variations.

The alternator (A) provides the power for the electronic box (B) mounted to it. The electronic box (B) rectifies the alternator's AC output to DC, stores the energy in a storage capacitor and contains an SCR switching device. When the external pick-up coil (C) is triggered by the rotating magnet (D) (either disc or flywheel mounted), the SCR in the electronic box is activated thus releasing the energy in the storage capacitor to the ignition coil (E) which steps-up the voltage to fire the spark plug.

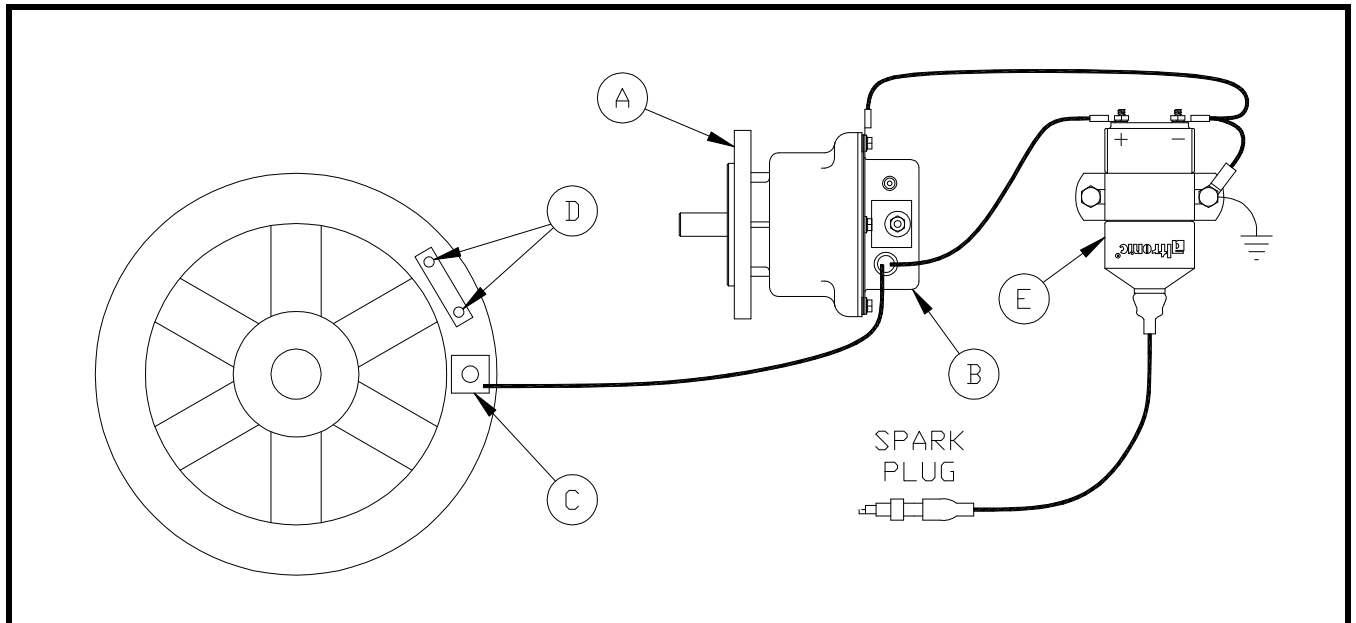

A. Alternator  
B. Electronic Box  
C. Pick-up Coil

D. Magnets - triggering  
E. Ignition Coil

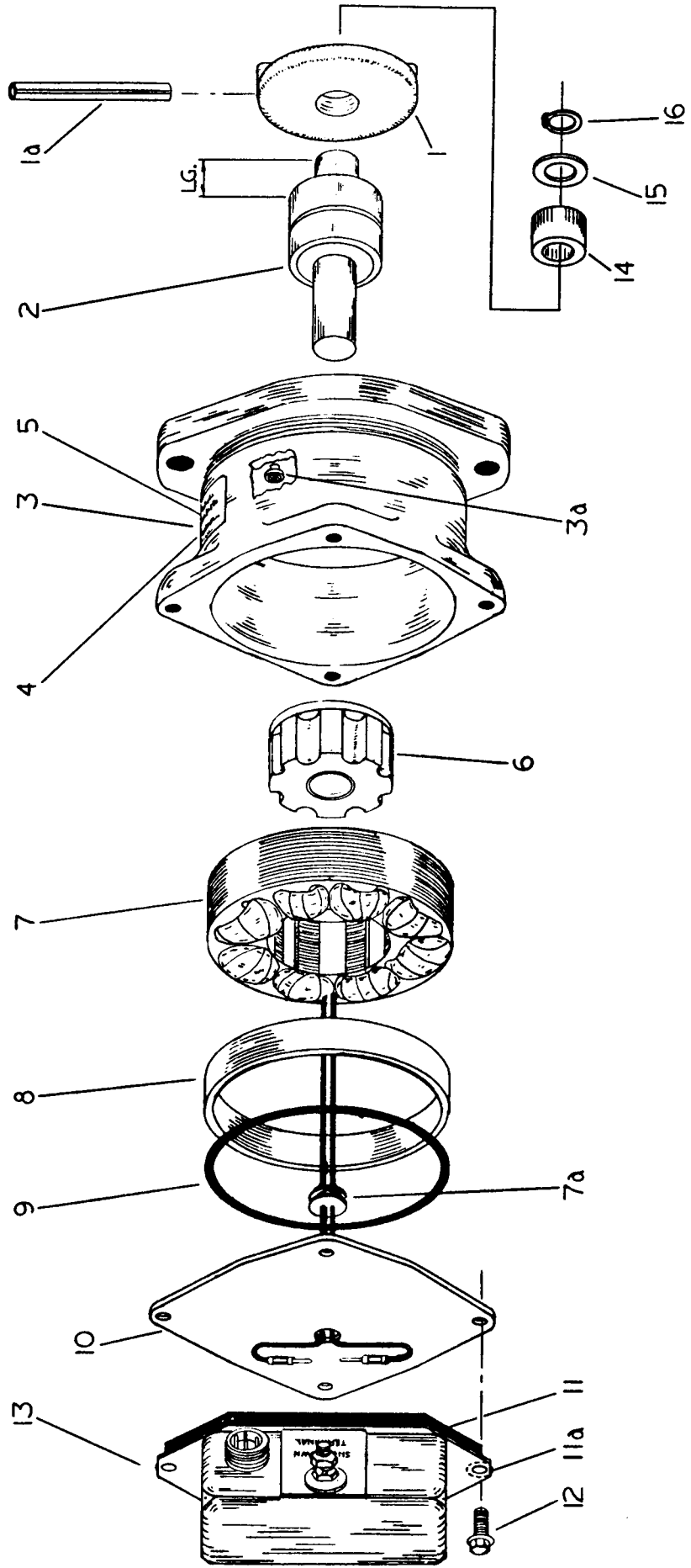

## 2.0 PARTS IDENTIFICATION AND SPECIFICATION

### 2.1 PARTS LIST - ALTRONIC I UNIT - Reference the exploded view on page 4.

REF. NO.	QTY.	PART NO.	DESCRIPTION
1	1	510454-U	Coupling - yellow
1a	1	902478	Spring pin 2-1/8" lg.
2	1	See below and page 6	Bearing-shaft
3	1	See page 6	Housing
3a	1	510541	Ventilator
4	1	102103	Nameplate
5	1	102106	Part no. decal
6	1	160001	Magnet-rotor assembly
7	1	171001	Stator - red leads
		171003	Stator - blue leads
7a	1	110447	Grommet
8	1	110453	Spacer
9	1	510462	O-ring
10	1	110452	Cover
11	1	110474	Gasket kit
11a	2	901317	Washer
12	4	902480	Screw 10-24 X 1/2"
13	1	See page 6	Electronic box
13a	2	503105	Tubing, plastic
14	1	410045	Sleeve
15	1	902503	Washer
16	1	902487	Snap ring

NOTE: Reference numbers with a letter suffix are part of the assembly of the same number without the suffix. Example: (1a) is part of (1).

### 2.2 BEARING-SHAFT IDENTIFICATION

BEARING-SHAFT PART NO. (2)	BEARING EXTENSION LENGTH
110459	0.55"
110465	1.03"
110466	0.85"
110467	1.46"
110471	1.33"

## 2.3 UNIT SPECIFICATIONS

A. TYPE indicates the alternator model and the number of system outputs. Example: G1 is Model G, 1 output. This is also the first two digits of the kit number using this model unit (G1-X-1).

UNIT NO.	TYPE	(12) ELEC. BOX	ALTERNATOR	(7) STATOR	(3) HOUSING	(2) BRG. SHAFT	VENT POS.
190003	G1	181001-X	180003-1	171001	110462	110459	1
190004	G2	181002-X	180003-1	171001	110462	110459	1
190005	C1	181001-X	180005-1	171001	110462	110467	1
190006	D1	181001-X	180006-1	171001	110463	110465	1 & 2
190007	F1	181001-X	180007-1	171001	110464	110466	1
190008	C3	181006	180005-2	171003	110462	110467	2
190011	G3	181006	180003-2	171003	110462	110459	1
190017	C1	181004	180005-2	171003	110462	110467	1
190022	W3	181006	180008-2	171003	110462	110471	1
190023	G3	181006-X	180003-1	171001	110462	110459	1
190026	D3	181006	180009	171003	110463	110459	1
190029	C3	181006-X	180005-1	171001	110462	110467	1

B. VENT POS. in the chart above determines the orientation of the electronic box when mounted to the alternator (see below).

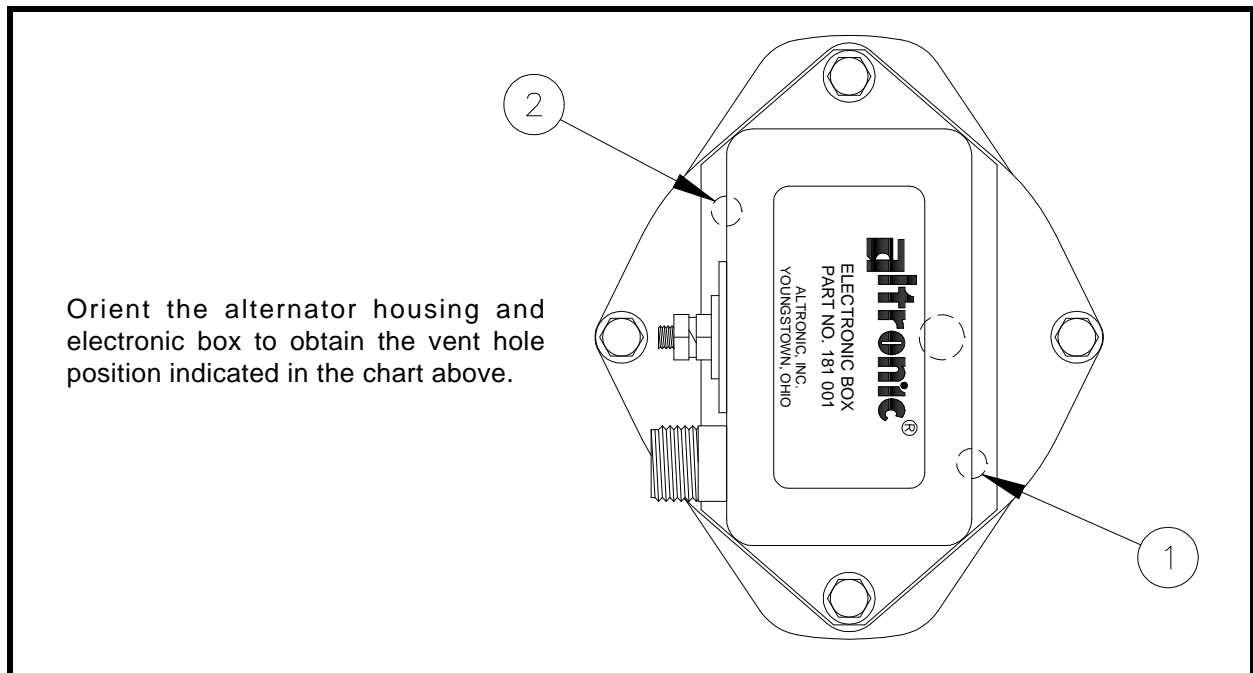

### 3.0 PERFORMANCE AND TEST SPECIFICATIONS

#### 3.1 BENCH TEST - ALTRONIC I

A. Connect the complete system as shown below. Turn the alternator shaft one or more revolutions by hand; then push the pick-up coil down squarely against the flush magnet of the magnet bar. A spark should jump a 7 mm gap as shown. If the performance test is failed, proceed to step 3.1D. below.

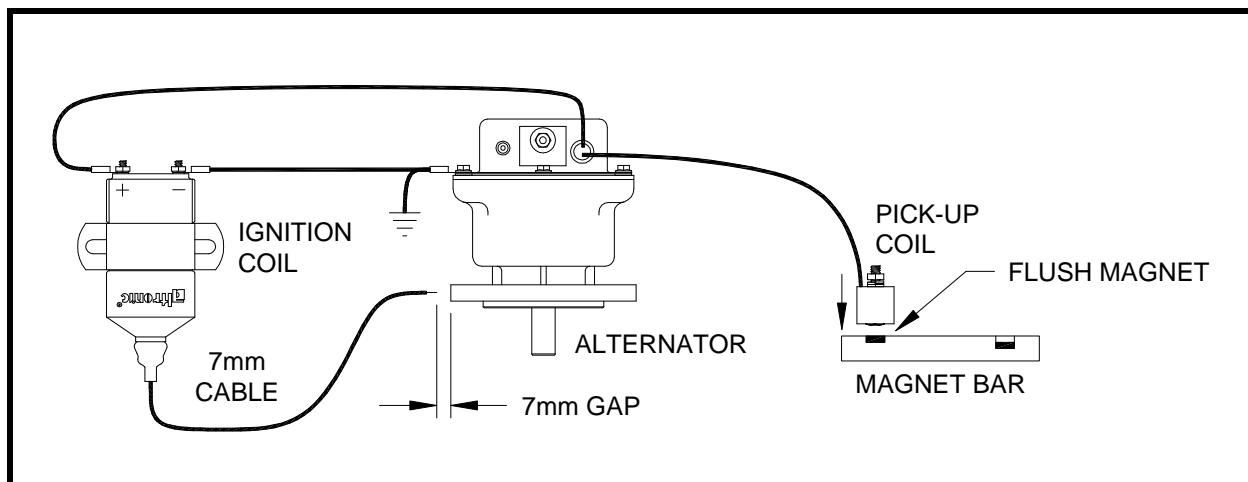

B. Connect the voltmeter to the electronic box as indicated below; turn the alternator shaft one or more revolutions by hand:

POSITIVE METER LEAD	NEGATIVE METER LEAD	METER SCALE	READING
Center terminal of Elec. Box	Ground	250 VDC	101074 Box - 105-126 VDC
			101077 Box - 105-126 VDC
			181001 Box - 143-157 VDC
			181001-X Box - 170-190 VDC
			181002 Box - 143-157 VDC
			181002-X Box - 170-190 VDC
			181004 Box - 130-157 VDC

C. If tests 3.1A. and 3.1B. are passed, the Altronic I unit is OK.

D. If either 3.1A or 3.1B is failed, the problem may be in the alternator stator (7) or electronic box (13). Remove the two screws (12) holding box (13) to the alternator. Check the connections between the box and alternator. If OK, unplug the stator leads from the electronic box.

#### 3.2 STATOR - ALTRONIC I

A. Check stator winding (7) with ohmmeter as follows:

POSITIVE METER LEAD	NEGATIVE METER LEAD	METER SCALE	READING
Stator lead	Stator lead	R X 10,000	171001 - 4,300-5,300 ohms
			171003 - 980-1,220 ohms
Stator lead	Alt. case	R X 10,000	171001 - Infinite
			171003 - Infinite

NOTE: The 171001 stator has RED leads; 171003 has BLUE leads. Replace stator if defective.

### 3.3 ELECTRONIC BOX 101074, 101077, 181001, 181001-X, 181002, 181002-X, 181004.

- A. If the stator checks OK (section 3.2) but the system fails either test 3.1A. or 3.1B., replace the electronic box (13).
- B. The tests below apply to types 101074, 101077, 181001, 181001-X, 181002, 181002-X and 181004.
- DO NOT short connector pins to case with the box mounted on the alternator.
  - Remove the box from the alternator for all tests; short center terminal to case before commencing the tests below.

POSITIVE METER LEAD	NEGATIVE METER LEAD	METER SCALE	READING
Shutdown terminal	Case	R X 10,000	Infinite or charging to final infinite reading.
Socket for stator lead	Other socket	R X 10,000	Meter should show capacitor charging (about 5 secs.) to final infinite reading.
Case	Connector pin "A"	R X 10,000 R X 10,000	Meter should give slight deflection with final infinite reading.
Connector pin "B"	Connector pin "C"	R X 100	101074, 101077 - 430-510 ohms 181001, 181002 - 430-510 ohms 181001-X, 181002-X - 430-510 ohms 181004 - 750-1,100 ohms

### 3.4 PICK-UP COIL AND CABLE ASSEMBLY - ALTRONIC I

- A. Check at pick-up coil connector with ohmmeter as follows:

POSITIVE METER LEAD	NEGATIVE METER LEAD	METER SCALE	READING
Connector pin "B"	Connector pin "C"	R X 100	800-1,700 ohms
Connector pin "B" or "C"	Connector pin "A"	R X 10,000	Infinite
Connector pin "A", "B", "C"	Connector shell	R X 10,000	Infinite

- B. Connector wiring and assembly should be as indicated below.

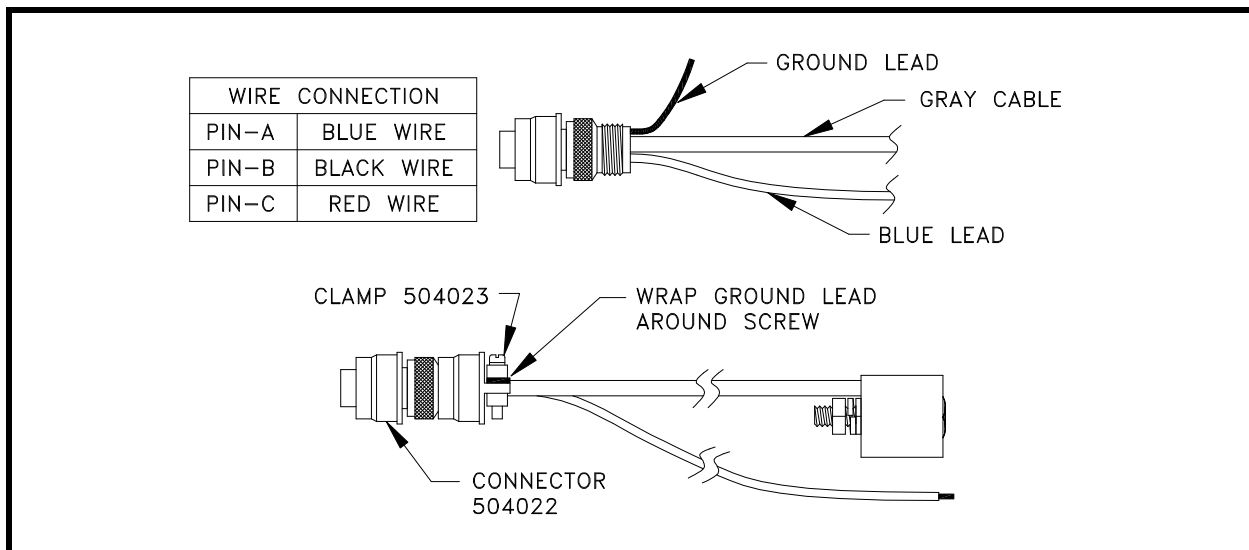



### 3.5 BENCH TEST - ALTRONIC I-6

A. Connect the complete system as shown below. Turn the alternator shaft one or more revolutions by hand; then push the magnet bar down squarely against the "A" pick-up of the pick-up module. A spark should jump a 7 mm gap as shown. Repeat the sequence above using "B" and then "C" pick-up. If the performance test is failed, proceed to step 3.5D. below.

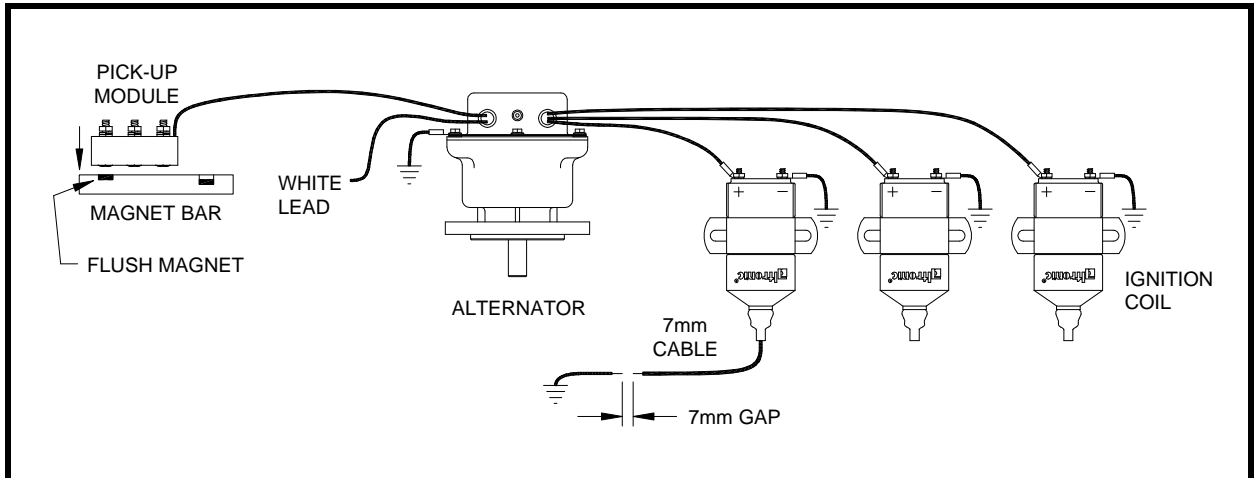

B. Connect the voltmeter to the electronic box as indicated below; turn the alternator shaft one or more revolutions by hand:

POSITIVE METER LEAD	NEGATIVE METER LEAD	METER SCALE	READING
White lead of 5-pin plug	Ground	250 VDC	181003 Box - 105-126 VDC
			181003-X Box - 130-158 VDC
			181006 Box - 142-158 VDC
			181006-X Box - 170-190 VDC

C. If tests 3.5A. and 3.5B. are passed, the Altronic I-6 unit is OK.

D. If either 3.5A or 3.5B is failed, the problem may be in the alternator stator (7) or electronic box (13). Remove the two screws (12) holding box (13) to the alternator. Check the connections between the box and alternator. If OK, unplug the stator leads from the electronic box.

### 3.6 STATOR - ALTRONIC I-6

A. Check stator winding (7) with ohmmeter as follows:

POSITIVE METER LEAD	NEGATIVE METER LEAD	METER SCALE	READING
Stator lead	Stator lead	R X 10,000	171001 - 4,300-5,300 ohms
			171003 - 980-1,220 ohms
Stator lead	Alt. case	R X 10,000	171001 - Infinite
			171003 - Infinite

NOTE: The 171001 stator has RED leads; 171003 has BLUE leads. Replace stator if defective.

### 3.7 ELECTRONIC BOX 181003, 181003-X, 181006, 181006-X

- A. If the stator checks OK (section 3.6) but the system fails either test 3.5A. or 3.5B., replace the electronic box (13).
- B. The tests below apply to types 181003, 181003-X, 181006, 181006-X.
1. DO NOT short connector pins to case with the box mounted on the alternator.
  2. Remove the box from the alternator for all tests; short terminal "E" of the 5-pin plug to case before commencing the tests below.

POSITIVE METER LEAD	NEGATIVE METER LEAD	METER SCALE	READING
Shutdown terminal	Case	R X 10,000	Infinite or charging to final infinite reading.
Socket for stator lead	Other socket	R X 10,000	Meter should show capacitor charging (about 5 secs.) to final infinite reading.
Case	3-pin connector pin "A", "B", "C"	R X 10,000	Meter should give slight deflection with final infinite reading.
5-pin connector pin "A", then "B", then "C",	3-pin Connector pin "A", then "B", then "C",	R X 100	180-200 ohms - OK 0-150 ohms - faulty

### 3.8 PICK-UP COIL AND CABLE ASSEMBLY - ALTRONIC I-6

- A. Check at pick-up module connector with ohmmeter as follows:

POSITIVE METER LEAD	NEGATIVE METER LEAD	METER SCALE	READING
Connector pin "D"	Connector pin pin "A", "B", "C"	R X 10,000	Infinite
Connector pin "E"	Connector shell	R X 10,000	Infinite

#### 4.0 SERVICE - ALTRONIC I UNIT

- A. The Altronic I unit breaks down into two major parts: alternator and electronic box. Remove the two screws (12) holding the electronic box (13) to the alternator. Unplug the two alternator leads from the electronic box and separate the box from the alternator.
- B. The procedures of this section require the use of an arbor press.

#### 4.1 DISASSEMBLY - ALTERNATOR

- A. Remove the two remaining screws (12) holding the cover plate (10) to the alternator. Loosen O-ring (9) from housing (3).
- B. Holding the assembly with the flange end up, remove stator (7), spacer (8), O-ring (9) and cover (10) as a group; a vertical shaking motion will help to accomplish this.
- C. Separate the stator leads and grommet (7a) from the cover (10).

#### 4.2 DISASSEMBLY - FRONT HOUSING ASSEMBLY

- A. 190022 UNIT ONLY: Remove hardware (15), (16) and sleeve (14) from the unit shaft.
- B. Drive spring pin (1a) out of coupling (1) and shaft (2) and remove coupling.
- C. If it is necessary to replace bearing-shaft (2), support housing on the coupling end and press shaft out of the magnet-rotor assembly (6) and housing (3).
- D. Wrap magnet-rotor (6) in a cloth or paper to keep it clean.

#### 4.3 REASSEMBLY - FRONT HOUSING ASSEMBLY

- A. Press a new bearing-shaft (2) into housing (3) until it bottoms against the shoulder. Housing (3) should be supported behind the internal shoulder (tool no. 506101B). Press on the outer race of the bearing using tool no. 506101A.
- B. Clean all debris from magnet-rotor assembly (6).
- C. Slide magnet-rotor assembly (6) over shaft with its plate facing inward as shown below. Support the shaft on the coupling end (tool no. 506102B) and press magnet-rotor assembly on shaft .650" from the housing surface - see below.  
NOTE: If the fit is loose, apply epoxy glue to the bore of the magnet-rotor.
- D. Slide coupling (1) on the shaft and secure with spring pin (1a). Use tool no. 506108A for this purpose.
- E. 190022 UNIT ONLY: Install sleeve (14) and engine gear. Secure with hardware (15) and (16).

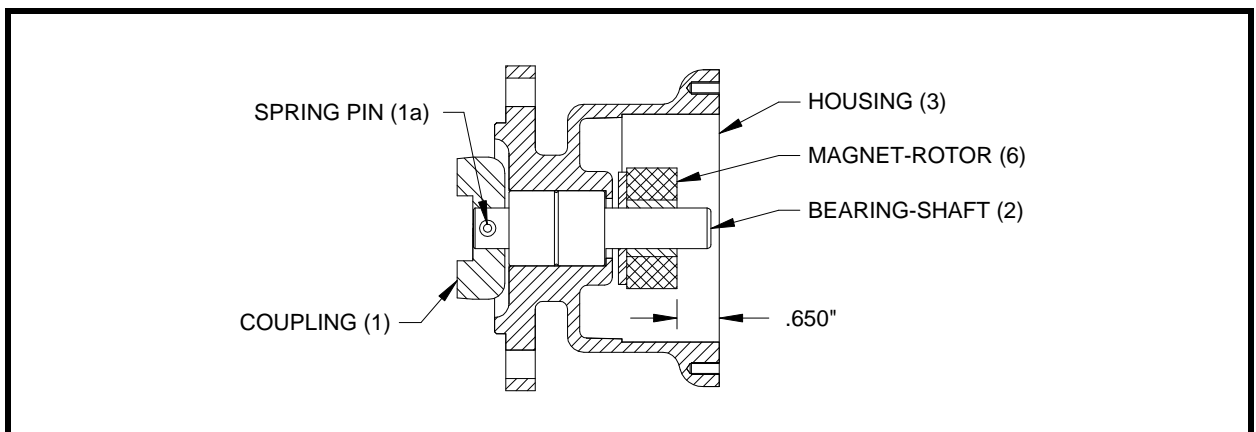

#### 4.4 REASSEMBLY - ALTERNATOR

- A. Install stator (7) so that the leads will pass directly up through the cover hole without crossing over the shaft. See page 6 for the correct orientation of the housing ventilator position.
- B. Install spacer (8) and a new O-ring (9).
- C. Insert stator leads and grommet (7a) through the hole in cover (10).
- D. Position cover so that the four screw holes line up with the alternator; install and tighten the two screws (12) that do not secure the electronic box.
- E. Check that the O-ring (9) is not caught between the cover (10) and the mounting surface of housing (3).

#### 4.5 REASSEMBLY - ELECTRONIC BOX TO ALTERNATOR

- A. Be sure the alternator assembly has the correct ventilator orientation with respect to the stator lead position - see page 6.
- B. Gasket installation:
  1. Box without attached gasket: position a new gasket (11) and washers (11a).
  2. Box with attached gasket: glue on a new gasket (11) in the case of a previously used box; the loose washers (11a) are not used.
- C. With the electronic box (13) positioned as shown below, connect the stator leads to the electronic box sockets. Slide tubing (13a) over the two mating pieces. Position the electronic box leads flat against the epoxy compound in the box as shown below. Carefully lay the box in position on the alternator making sure the leads stay in the position shown.
- D. Secure the box to the alternator with two screws (12); be sure all four screws (12) are tight.

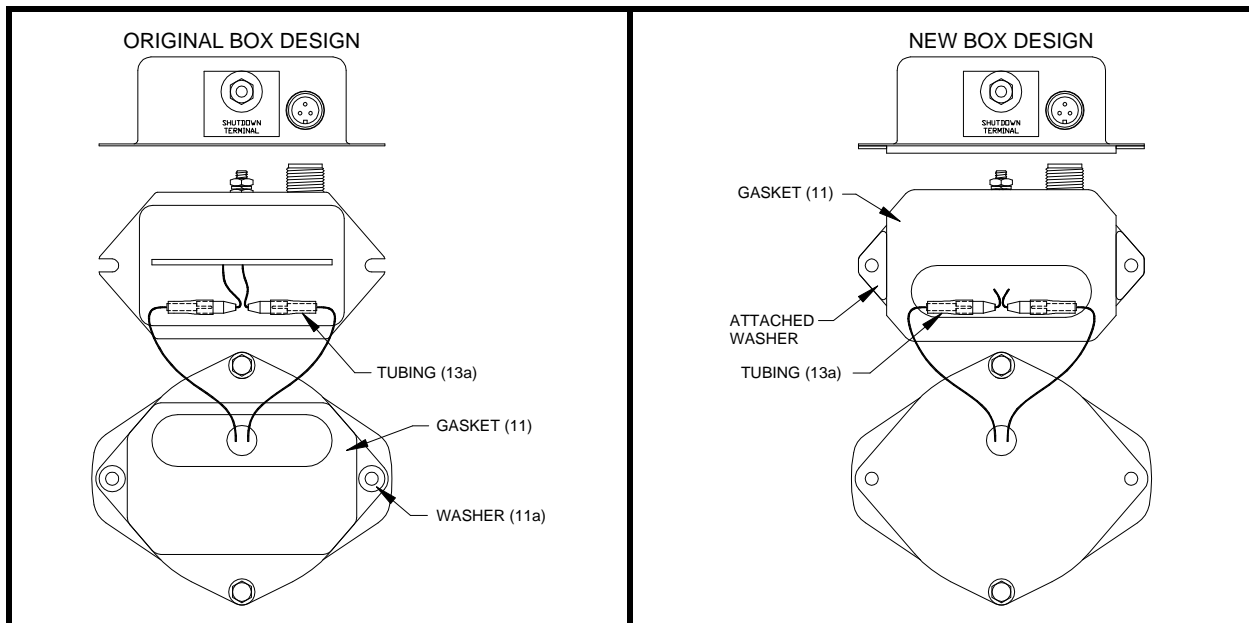

#### 5.0 SERVICE - ASSEMBLY TOOLS

- A. The assembly tools referred to in section 4.3 are available from Altronic.

#### 6.0 OPERATIONAL TEST

- A. Check for correct operation per the test of section 3.1 or 3.5.