

Model MTH6 Tach/Hourmeter Overspeed Switch Installation and Operation Instructions



Please read the following information before installing. A visual inspection of this product for damage during shipping is recommended before mounting. It is your responsibility to have a qualified person install this unit.

GENERAL INFORMATION

! **WARNING**

BEFORE BEGINNING INSTALLATION OF THIS MURPHY PRODUCT

- ✓ Disconnect all electrical power to the machine.
- ✓ Make sure the machine cannot operate during installation.
- ✓ Follow all safety warnings of the machine manufacturer.
- ✓ Read and follow all installation instructions.

Description

Microprocessor-based digital tachometer and hourmeter with a built-in overspeed switch. This Murphy instrument is highly accurate and dependable. It measures speed and running hours and can give an alarm or shut down the engine on overspeed.

RPM data for the tachometer and overspeed switch is supplied by a magnetic pickup or a battery charging alternator equipped with a "Tach" terminal (auxiliary AC terminal). The magnetic pickup is installed into the fly-wheel housing of an internal combustion engine, so that the starter ring gear acts upon it to generate a voltage pulse each time a gear tooth passes the end of the magnetic pickup.

Specifications

Power Requirements: 8-40 VDC (12, 24 or 32 VDC system).

Maximum Current:

12 VDC: 0.011 A, backlight Off; 0.025 A, backlight On.

24 VDC: 0.008 A, backlight Off; 0.015 A, backlight On.

32 VDC: 0.007 A, backlight Off; 0.010 A, backlight On.

Operating Temperature: -4° to 158°F (-20° to 70°C).

Storage Temperature: -40° to 185°F (-40° to 85°C).

Case: 1018 Polycarbonate/Polyester blend.

Speed Input: 4.5 Vrms minimum.

Input Frequency Range: 25 Hz to 20 kHz.

Overspeed Switch Rating: 2 A, 50 VDC.

Overspeed Range: 0 to 9000 kHz.

Pulses per Revolution: 4 to 255.

Tachometer Range: 0 to 65,535 RPM.

Tachometer Accuracy: ±1% of display reading, or -2 RPM whichever is greater.

Hourmeter Range: 0 to 99999 hrs.

Hourmeter Resolution: ±0.1 hour to 9999.9; ±1 hour 10,000 and up.

Reset Hourmeter: Ground terminal #5 to reset hours to zero.

Shipping Weight: 14 oz. (435 g).

Shipping Dimensions: 5-1/2 x 5-1/2 x 5-1/2 in. (140 x 140 x 140 mm).

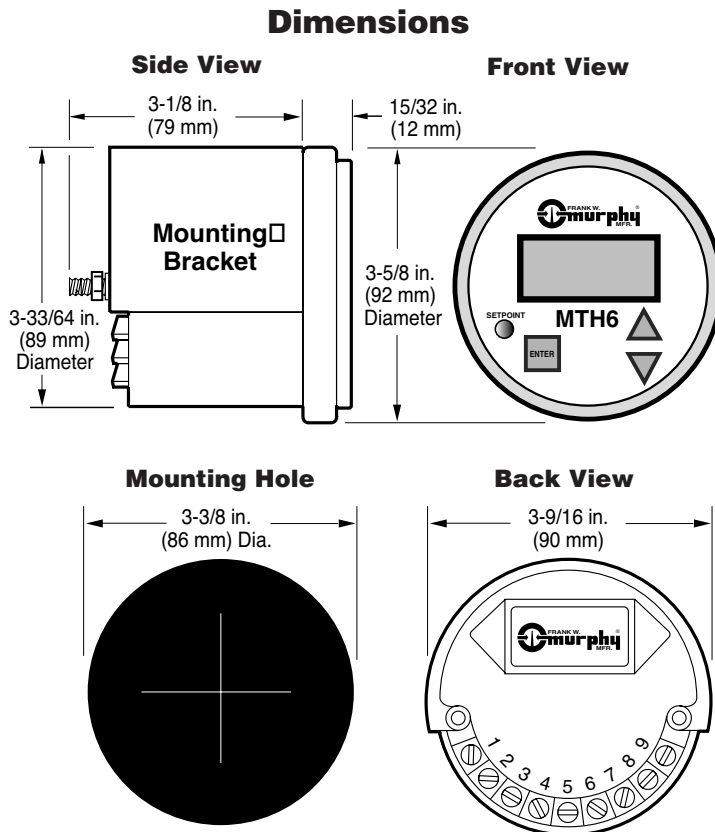

MTH6 Mounting Schematic

To mount the MTH6 to your panel, a 3-3/8 in. (86 mm) diameter mounting hole is required. Remove the mounting bracket and lock nuts (provided with the unit).

Insert the MTH6 module from the front of the panel, see schematic below. Replace mounting bracket and secure in place with the lock nuts.

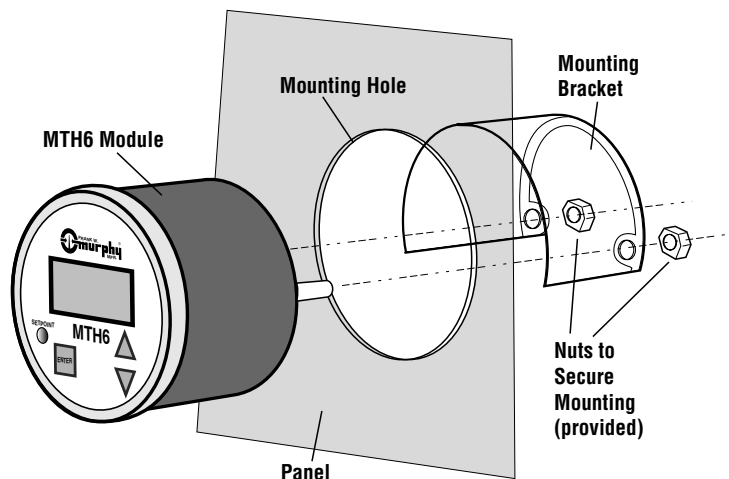

WARNING: Disconnect All Power before performing wiring operation. Keep power leads away from input leads.

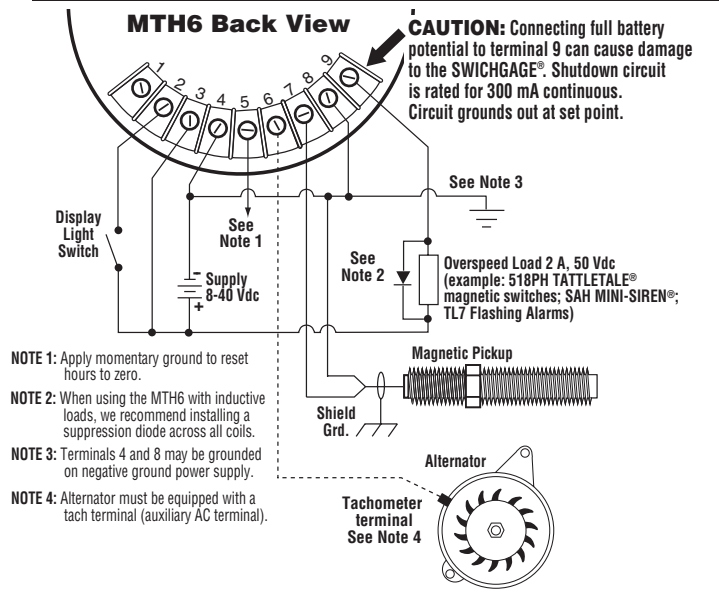

Wiring the MTH6 Refer to Typical Wiring Diagram, below. Operation Sequence and Adjustments

When power is applied, the MTH6 performs an LCD test displaying 9999.9 counting down to zero within 3 seconds. The MTH6 will perform a normal scan, and will begin to monitor engine RPM. When the unit is in Normal Scan, it displays RPM. The display is updated internally every second.

Viewing the Elapsed Time Hours (Hr-S)

1. To view the elapsed hours, press **ENTER** (■) while in Normal Scan.
2. Hr-S will be displayed followed by elapsed hours.
3. To clear/reset to zero, apply a momentary ground to terminal #5. The hourmeter cannot be reset when a speed signal is present (normal operation).

NOTE: When speed input is present the first digit and decimal point will flash. Decimal point will NOT appear after 10,000 hours have elapsed.

Pulses Per Revolution (P-r-E-U) Calibration

1. To view the current pulses per engine revolution, press **ENTER** (■) while in Normal Scan. Hr-S will be displayed followed by the running hours.
2. Press **ENTER** (■). P-r-E-U will be displayed followed by the present number of pulses per revolution. The factory setting is 60. Unit will display input frequency with this setting.

MTH6 Module Detail

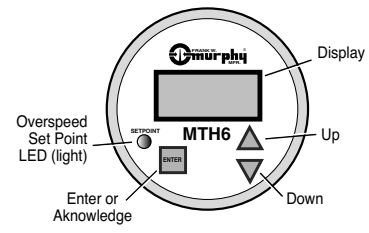

3. To calculate the pulses per engine revolution (P-r-E-U) follow the instructions:
 - Magnetic Pickup:** Determine the number of teeth on the engine's flywheel. The number of teeth is equal to the number of pulses per engine revolution.
 - Battery Charging Alternator:** Multiply the ratio of alternator to engine pulley diameter, times, the number of poles of the alternator divided by 2 to determine the correct pulses per engine revolution.
 When the number of pulses per revolution is unknown, follow this procedure:
 1. Set the pulses per revolution on the MTH6 to "60".
 2. Run the engine at a constant speed and measure the actual RPM using a handheld tachometer or any means which measures actual RPM.
 3. Read the RPM displayed on the MTH6 (this is the frequency in hertz caused by the engine speed).
 4. Multiply the RPM reading on the MTH by 60, then divide by the actual RPM read by the handheld device. Set this resulting number as the pulses per revolution on the MTH6.

NOTE: If pulses per revolution are not a whole number, for example: 21.5, a setting of 21 will read slightly high and a setting of 22 will read slightly low.

4. To change the P-r-E-U setting first remove the input signal. Press **UP** (▲) to increase the value. Press **DOWN** (▼) to decrease the value.
5. Once the number of pulses per revolution is set, press **ENTER** (■) to save. SAVE is displayed indicating that the new number is saved.
6. Connect the input signal back in place (refer to typical wiring diagram at left).

Overspeed Set Point (HISP) Calibration

1. To view the current Overspeed set point, press **ENTER** (■) while the MTH6 is in Normal Scan.
2. Hr-S will be displayed followed by the amount of elapsed hours.
3. Press **ENTER** (■) with elapsed time visible. P-r-E-U will be displayed followed by the number of pulses per revolution.
4. Press **ENTER** (■). HISP will be displayed followed by the overspeed set point previously entered. Factory setting is 1500.
5. Press **UP** (▲), to increase the overspeed setting. Press **DOWN** (▼) to decrease the setting.
6. Press **ENTER** (■), SAVE will be displayed indicating that the new value is now saved.

Warranty

A limited warranty on materials and workmanship is given with this FW Murphy product. A copy of the warranty may be viewed or printed by going to www.fwmurphy.com/support/warranty.htm



FW Murphy
 P.O. Box 470248
 Tulsa, Oklahoma 74147 USA
 +1 918 317 4100 fax +1 918 317 4266
 e-mail sales@fwmurphy.com
www.fwmurphy.com

INDUSTRIAL PANEL DIVISION
 P.O. Box 470248
 Tulsa, Oklahoma 74147 USA
 +1 918 317 4100 fax +1 918 317 4266
 e-mail sales@fwmurphy.com

MURPHY DE MEXICO, S.A. DE C.V.
 Blvd. Antonio Rocha Cordero 300, Fraccion del Aguaje
 San Luis Potosi, S.L.P.; México 78384
 +52 444 8206264 fax +52 444 8206336
 Villahermosa Office +52 993 3162117
 e-mail ventas@murphymex.com.mx
www.murphymex.com.mx

FRANK W. MURPHY, LTD.
 Church Rd.; Laverstock, Salisbury SP1 1QZ; U.K.
 +44 1722 410055 fax +44 1722 410088
 e-mail sales@fwmurphy.co.uk
www.fwmurphy.co.uk



Printed in U.S.A.

In order to consistently bring you the highest quality, full featured products, we reserve the right to change our specifications and designs at any time.