



Sentry Battery Charger

Installation and Operations Manual

00-02-0616
03-03-08
Section 75

In order to consistently bring you the highest quality, full featured products, we reserve the right to change our specifications and designs at any time. The latest version of this manual can be found at www.fwmurphy.com.

Warranty - A limited warranty on materials and workmanship is given with this FW Murphy product. A copy of the warranty may be viewed or printed by going to www.fwmurphy.com/support/warranty.htm



Please read the following information before installing.

BEFORE BEGINNING INSTALLATION OF THIS MURPHY PRODUCT:

- Disconnect all electrical power to the charger.
- Make sure the charger cannot operate during installation.
- Follow all safety warnings of charger and battery manufacturers.
- Read and follow the Safety Instructions section of this manual.
- Read and follow all installation instructions.
- Please contact FW MURPHY immediately if you have any questions.

Table of Contents

Safety Instructions	1
General Safety Instructions	1
Personal Precautions	2
Prior to Installation / Commissioning	3
Charger Location and Connection.....	3
General Product Information	4
Installation and Mounting Instructions	6
Operating Instructions	7
Terminal Connection Information	7
Charger Connectivity.....	8
Troubleshooting	10
Measuring Charging Voltage and Current.....	11
Output Voltage	11
Using Correct Size Battery Charger	12
Factors Contributing to Electrolyte Loss.....	12
Battery Life	12
Specifications	14
Power Supply	14
DC Charge Output	14
Charge Fail Output.....	14
General	14

NOTES

Safety Instructions

This manual contains important safety and operating instructions for the Sentry battery charger.

General Safety Instructions

For safe and correct use of the unit, follow the steps below. Should you have any problems and the unit does not function as expected, consult the “Troubleshooting” section located at the end of this manual.

- Visually inspect unit for any signs of damage caused by transport or storage. Do not operate charger if it has received a sharp blow, been dropped, or otherwise damaged in any way. Return to supplier in this event.
- Mount charger as outlined in “Charger Location and Connection”, paying attention to ambient temperature.
- Ensure main power supply is disconnected, then connect charger, observing the correct rated input voltage.
- Ensure unit is properly grounded.
- Check batteries in accordance with manufacturer guidelines.
- Ensure charger is correct for battery type and voltage.
- Connect unit to batteries, observing correct polarity and ensuring a secure and tight connection.
- Switch on unit at main supply.
- Do not expose charger to rain or snow.
- Use of an attachment not recommended or sold by the battery charger manufacturer may result in risk of fire, electric shock, or injury to persons.
- Do not disassemble charger. Return to supplier when service or repair is required. Incorrect reassembly may result in a risk of electric shock or fire.

WARNING – RISK OF EXPLOSIVE GASES

WORKING IN VICINITY OF A LEAD-ACID BATTERY IS DANGEROUS. BATTERIES GENERATE EXPLOSIVE GASES DURING NORMAL BATTERY OPERATION. To reduce the risk of battery explosion, follow these instructions and those published by battery manufacturers and the manufacturers of any equipment you intend to use in vicinity of the battery. Review cautionary markings on these products and on any attached equipment.

Personal Precautions

- Someone should be within range of your voice or close enough to come to your aid when you work near a lead-acid battery.
- Have plenty of fresh water and soap nearby in case battery acid contacts skin, clothing or eyes.
- Wear complete eye protection and clothing protection. Avoid touching eyes while working near batteries.
- If battery acid contacts skin or clothing, wash immediately with soap and water. If acid enters eyes, immediately flood eyes with running cold water for at least 10 minutes and get medical attention immediately.
- NEVER smoke or allow a spark or flame in vicinity of battery.
- Be extra cautious to reduce risk of dropping a metal tool onto battery. It may spark or short-circuit the battery or other electrical part that may cause explosion.
- Remove personal metal items such as rings, bracelets, necklaces, and watches when working with a lead-acid battery. A lead-acid battery can produce a short-circuit current high enough to weld a ring or the like to metal, causing a severe burn.
- Use charger only for charging batteries as stated on the charger. Do not use battery charger for charging dry-cell batteries that are commonly used with home appliances. These batteries may burst and cause injury to persons and damage to property.
- NEVER CHARGE A FROZEN BATTERY.

Prior to Installation / Commissioning

- Clean battery terminals. Be sure to keep corrosion from coming in contact with eyes.
- Add distilled water in each cell until battery acid reaches level specified by battery manufacturer. This helps purge excessive gas from cells. Do not overfill. For a battery without cell caps, carefully follow manufacturer's recharging instructions.
- Study all battery manufacturers' specific precautions such as removing or not removing cell caps while charging and recommended rates of charge.
- Determine voltage of battery by referring to engine manual and ensure it matches charger's output voltage.

Charger Location and Connection

- Never place charger directly above battery being charged as gases from battery will corrode and damage charger.
- Never allow battery acid to drip on charger when reading specific gravity or filling battery.
- Do not operate charger in a closed-in area or restrict ventilation in any way.
- The battery charger should be connected to a grounded, metal, permanent wiring system.
- Connections to battery charger should comply with all local codes and ordinances.
- AC wiring should be run separately from the output of the charger and the alarm wiring. Use 12 gauge or larger wire from the charger to the battery. Use 14 gauge or larger wire for input and ground connections.

General Product Information

Please read the following information before installing.

A visual inspection of this product for damage during shipping is recommended before installation.

It is your responsibility to ensure that qualified mechanical and electrical technicians install this product.

The Sentry battery charger provides automatic, current limited and voltage controlled charging of vented lead acid batteries. They may be used in a wide range of industrial charging applications, including standby engines, pumps and generators.

The charger is supplied in an open frame construction, designed for surface mounting in an enclosed panel with charging indication via an ammeter and voltmeter. Each unit consists of a transformer, rectifier and thyristor control circuit. The control circuit ensures that the charger maintains a battery voltage at the pre-calibrated float level, while supplying any additional load current up to the specified maximum.

Auto Boost (Equalizing) Operation

Auto boost operation provides an increased output voltage when batteries are below a preset point. Once the batteries have reached the boost voltage the charger reverts to its float voltage. This operation equalizes the batteries, maximizing battery life and capacity.

Boost Initiate Operation

The boost initiate switch forces the charger to enter an auto boost cycle even if battery voltage is above the preset point. Once this operation is completed the charger returns to its float voltage.

Temperature Compensation

The remote temperature compensation provides control of the output voltage based upon temperature. As temperature increases the charging voltage is decreased at a negative coefficient of $3\text{mV}/^{\circ}\text{F}/\text{Cell}$.

Charge Fail

A self diagnosis 'charge fail' circuit and relay output is provided. The volt-free relay de-energizes in the event of a charging fault.

Electrical connection of the AC and DC supply and alarms are via spring-clamp terminals.

Current Limiting

The Sentry battery charger is current limited and will only output a rated 5A of current.

Battery Charged Condition

When charged, the battery will only accept a charge to replace the losses within the battery (approximately 1mA per AH of battery). If there is a standing load (the control panel, etc.) the charger will output the standing load plus the losses to the battery. If a standing load of 1A is present with 50AH Vented Lead Acid batteries, then the charger will supply 1.05 amps.

A charged battery with open circuit terminals (no load connected) will always be higher than nominal battery voltage (12.6 on a 12V lead acid battery).

Dimensions

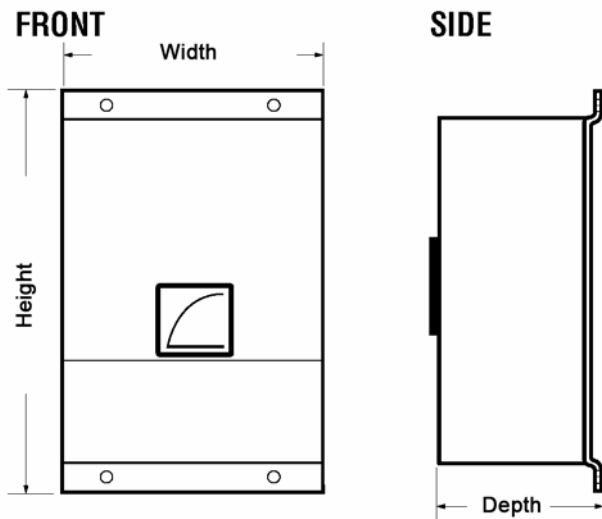

W	D	H	Weight
5.5" (140mm)	4.6" (115mm)	11.1" (281mm)	11.9 lbs. (5.6Kg)

Installation and Mounting Instructions

Mounting hole dimensions:

- Width (between holes) – 2.6" (66mm)
- Height (between holes) – 10.04" (255mm)
- Mounting holes – 0.2" (6mm)

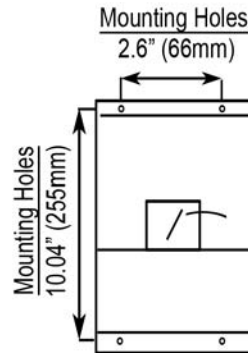

Wall Mounted Enclosure

- The charger must be mounted as shown in the figure above.
- The lower face is removed by unscrewing the two screws. The face is removed by sliding the face backward, thereby releasing the “feet” from their fixing holes.
- Conduit entry is via knock-outs on either side of the unit. These must be carefully removed from the enclosure sides.
- A suitable cable-gland (0.8”/20mm DIA) should be used to prevent damage to cables and stop unwanted entry into inner part of charger. See “Terminal Connection Information” section of the chapter on Operating Instructions for details of terminal connections.
- The lower face should be firmly screwed to the charger before use.
- Four sets of nuts, bolts, flat and lock washers should be used to mount the unit. Ensure bolts are tightened firmly.
- Adequate consideration should be given to ventilation for proper heat dissipation. The minimum clearances for proper venting are 12 inches on top, and 6 inches for bottom and sides.

CAUTION: When handling chargers, care should be taken not to place excessive strain on the protective aluminum back plate, PCB, transformer or connecting wires. Unit should be handled by the steel enclosure.

Operating Instructions

Before operating the battery charger, ensure that the charger is assembled and installed according to the installation instructions.

WARNING: DANGER OF INJURY OR DEATH

Before connection, disconnection or handling of Sentry battery charger, ensure that all AC power supplies are disconnected.

NOTE: Connection to or disconnection from live wiring can also cause damage to internal components.

Terminal Connection Information

OUTPUT		INPUT		CHARGE FAIL				BOOST	
+	-	N	L	Co	CoE	N/O	N/C	↓	↓

Output: To battery
CAUTION: Observe correct polarity

Input: AC supply
CAUTION: Observe correct voltage as stated on unit.

Charge Fail: **Com** – Common
N/O – Normally open
N/C – Normally closed

Stripped wire is introduced just before the clamping unit.

The clamp spring is pressed down and wire is introduced into the clamping unit immediately.

The clamp spring is released – the conductor is automatically clamped.

NOTE: All connections, including AC input and DC output are made via spring-clamp connections as outlined above.

The Sentry charger is fitted with a self-resetting polyfuse on the dc output. If reverse polarity or short circuit faults occur, remove AC power, disconnect the output(s) and allow poly-fuse to reset. The charger can then be re-connected and switched back on. No replacement of output fuse should be necessary. If fuse fails to reset, the charger should be returned to supplier.

Automatic Battery Charger

The Sentry charger range is an automatic battery charger. If battery voltage falls below a preset voltage (10.2V on a 12V lead-acid battery) the charger will automatically enter an increased charging voltage state (boost). Once the batteries have reached a charged state, the charger will switch to its normal “float” voltage. This prevents over-charge, which in turn prevents the battery from over-gassing and subsequently maximizes battery life.

WARNING! The Sentry charger is not user serviceable. No attempt should be made to replace or repair the charger. Any attempt to do so may invalidate any warranties and could cause serious personal harm or injury as well as damage to both the battery charger and any connected devices. In the event of failure the charger should be returned to the supplier.

Charger Connectivity

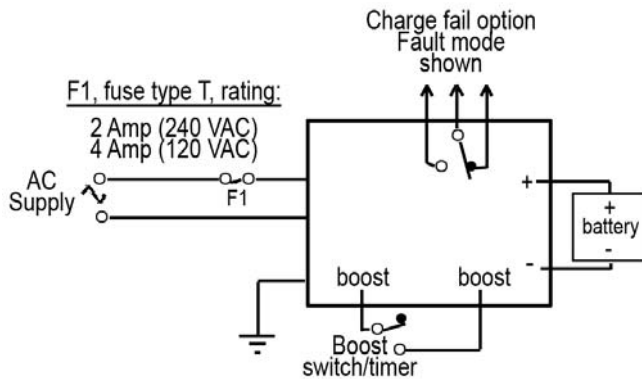

Connection to Utility Supply

Ensure AC power supply is off before connecting to the battery charger. Ensure that the unit is properly grounded at the grounding stud located to the left of the AC/DC terminal block on the chargers chassis.

CAUTION: Ensure correct AC voltage is supplied to unit. Applying 240VAC on a 120VAC unit will destroy it and could cause serious personal injury.

Connection to Batteries

Ensure AC supply is off before connecting charger to batteries. Ensure battery type and voltage are correct before connecting to batteries.

WARNING: Charging either different voltage or type of batteries from stated type may result in damage to both the charging unit and/or batteries and could result in serious personal injury.

Disconnection of Batteries

Ensure AC supply is isolated before disconnecting charger from batteries.

WARNING: Disconnecting the batteries while the power supply is connected to the charger could result in a spark at battery terminals, which could ignite the hydrogen given off from the batteries.

Boost Initiate Connection

The charger will be in its normal mode of operation while the boost link is broken. Upon connecting the two boost initiate terminals the charger will perform a single auto-boost cycle. While the charger outputs a higher voltage, once the battery voltage has reached this point, the charger returns to its normal float mode of operation.

Charge Fail Connection

In a de-energized state the COM – N/C contact is alarmed. The relay energizes on power up and changes state to COM – N/O. These dry contacts are rated at 1A @ 30VDC.

Fuses

The wall mounted enclosure is fitted with internal AC input fuses at the stated ratings. Before replacing any fuses, ensure AC power to the charger is off.

Troubleshooting

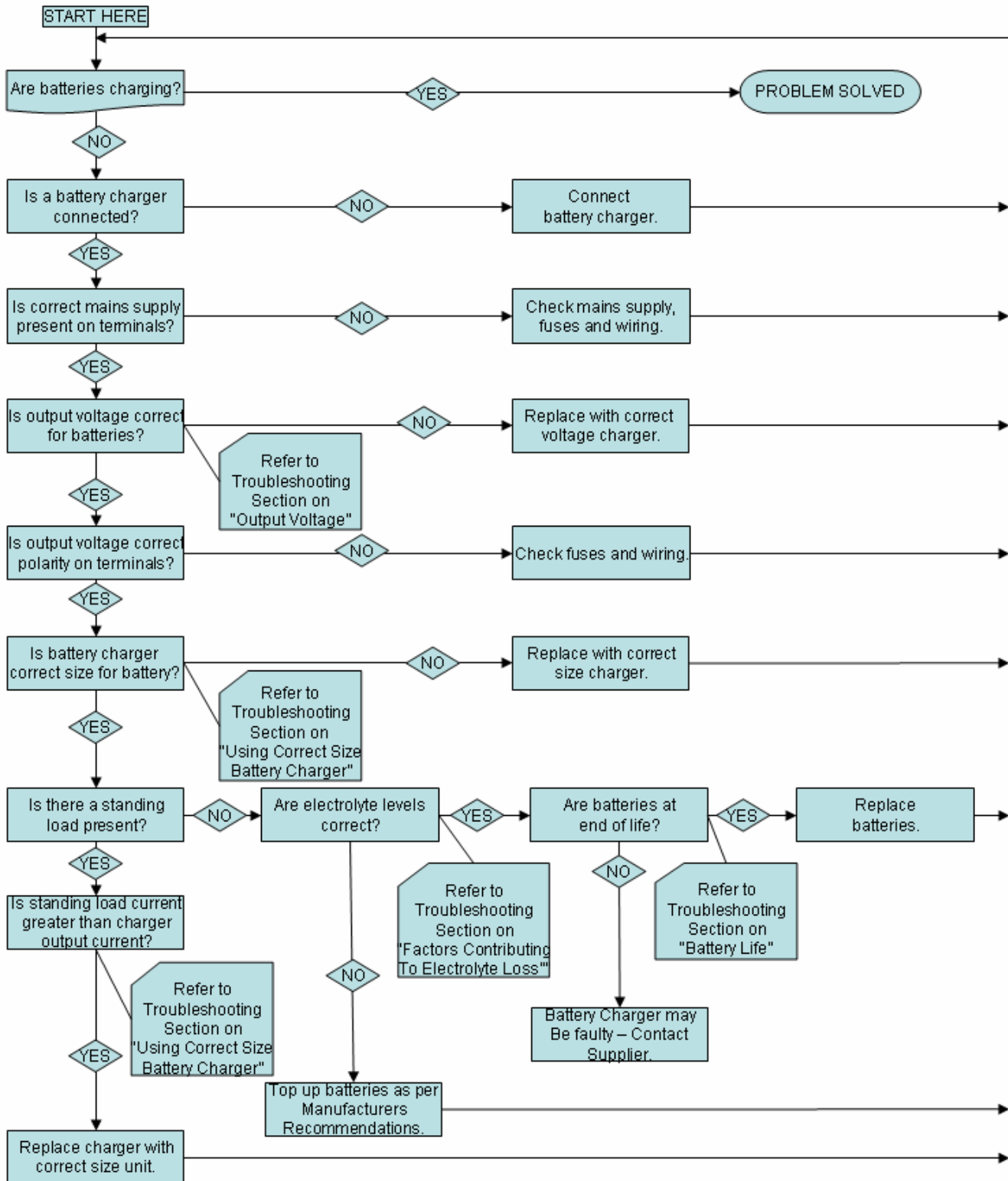

Measuring Charging Voltage and Current

To verify that the charger is working, follow these steps then consult the expected conditions listed below.

1. VOLTAGE – Place voltmeter across battery terminals (“V” in diagram).
2. CURRENT – Break the positive line to the battery and place an ammeter between positive from charger and positive of battery (“A” in diagram).

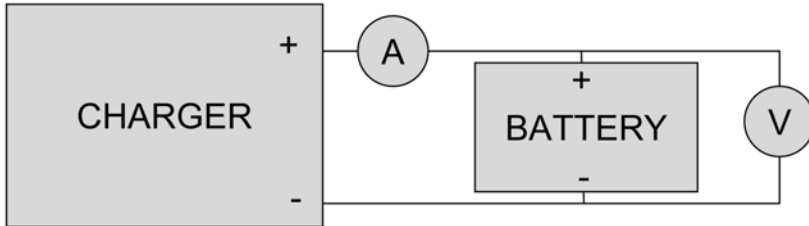

CAUTION: Only connect an ammeter in series with the power to the charger disconnected. Be very careful about connections to the battery, as it is live, and can short if considerable care is not taken.

Current Flow from Charger to Battery

If voltage at terminals is less than nominal battery voltage then the maximum rated charger current should be present.

NOTE: Once battery is fully charged, output current should be between 0.1% and 0.5% of batteries AH capacity plus any standing loads.

Voltage Rise at Battery Terminals

A gradual rise of voltage should be seen showing as float voltage is reached – batteries should not be boost charged continuously.

NOTE: If the battery voltage increases rapidly during charge and no minimum current is measured then the battery may have become sulphated and will not hold charge and may be unrecoverable.

Output Voltage

LEAD ACID		12/v	24/v
	Float:	13.6V	27.2V
	Boost:	14.1V	28.2V
Typical output with no battery or load connected. The pre-calibrated float voltage should be present.			

Using Correct Size Battery Charger

The battery charger will need to provide both the standing load and minimum charge current. If a charging current of 2A is required, and the standing load is 1A, then the charger needs to be able to output a total of 3 amps.

Refer to genset manual for sizing of battery chargers to generator set. If installing your own chargers, lead acid battery manufacturers recommend the following:

- Minimum charge current should be approximately 5% battery AH capacity.
- Maximum charge current to be equal to 25% battery AH capacity

NOTE: When batteries are normally charged by a charging alternator, a float battery charger rated at lower than the minimum charge current is sufficient to keep batteries in fully charged state.

Factors Contributing to Electrolyte Loss

- Physical damage to cells can cause electrolyte to leak or evaporate.
- High charging voltages will evaporate electrolyte.

Check charging voltage against battery type and voltage.

WARNING: If the batteries are being used at above 68° Fahrenheit, the chargers output voltage will be temperature compensated at - 3mV/°F/Cell.

Battery Life

Two possible methods can be used for determining battery life:

- Using Hydrometer
- Using a digital DC voltmeter

Follow these steps to check battery life.

1. Fully charge the batteries.
2. Disconnect batteries and leads and leave for 24 hours.
3. Measure either specific gravity (hydrometer) or terminal voltage (voltmeter) and compare with the table on the following page.

% Charge	Specific Gravity	Voltage (DC) on a 12V battery
100	1.265	12.8
75	1.225	12.5
50	1.19	12.4
25	1.155	12.0
Discharged	1.12	11.5

NOTE: If the voltage across the terminals shows around 10.5V, this may indicate a shorted cell is present.

- If time is limited due to on-site testing, remove surface charge by either applying a 20a load for 3 minutes or crank engine for 10 seconds, then disconnect batteries and leads and leave for minimum of 10 minutes.

NOTE: On this method, providing batteries have been sized correctly for engine and charged correctly, an open terminal voltage of 12.5V or greater should be present.

WARNING! Adjusting the potentiometers on the PCB may be cause for voiding warranty. They are factory set for the application stated on the label and are not meant to be adjusted by the user under any circumstances.

Specifications

Power Supply

- Nominal operating voltages – 120V Units
- Permissible voltage variation - $\pm 6\%$ of nominal
- Nominal operating frequency – 50/60Hz

DC Charge Output

- Maximum current ADC – 5
- Nominal voltage VDC – 12
- Float/boost voltages
These are factory preset for specified batteries, typical settings are as follows:

Vented lead acid – Float voltage – 13.6V
Vented lead acid – Boost voltage – 14.1V

Charge Fail Output

- Relay type – volt free SPDT dry contacts relay de-energized on fault.
- Contact rating – 1A @ 30VDC (resistive load)

General

- Transformer – Single phase 50-60 Hz Class 130
- Operating temperature - +14°C to +131°C (-10°C to +55°C)
- Wall mounted enclosure models
- Dimensions 11.1”(281mm)(H) x 5.5”(140mm)(W) x 4.6”(115mm)(D); weight 11.9 lbs / 5.6Kg
- EMC emission/immunity – EN58801-2 / EN50082-2

MURPHY and the Murphy logo are registered and/or common law trademarks of Murphy Industries, Inc. This document, including textual matter and illustrations, is copyright protected by Murphy Industries, Inc., with all rights reserved. (c) 2007 Murphy Industries, Inc. Other third party product or trade names referenced herein are the property of their respective owners and are used for identification purposes only.

FW MURPHY

P.O. Box 470248
Tulsa, Oklahoma 74147 USA
+1 918 317 4100 Fax: +1 918 317 4266
E-mail: sales@fwmurphy.com

INDUSTRIAL PANEL DIVISION

Fax: +1 918 317 4124
E-mail: ipdsales@fwmurphy.com

MURPHY POWER IGNITION

Web site: www.murphy-pi.com

www.fwmurphy.com

CONTROL SYSTEMS & SERVICES DIVISION

P.O. Box 1819
Rosenberg, Texas 77471 USA
Phone: +1 281 633 4500 Fax: +1 281 633 4588
E-mail: sales@fwmurphy.com

FRANK W. MURPHY, LTD

Church Rd Laverstock
Salisbury SP1 1QZ UK
Phone: +44 172 241 0055 Fax: +44 172 241 0088
E-mail: sales@fwmurphy.co.uk
Web site: www.fwmurphy.co.uk

COMPUTRONIC CONTROLS, LTD

41 - 43 Railway Terrace Nechells
Birmingham B7 5NG UK
Phone: +44 121 327 8500 Fax: +44 121 327 8501
E-mail: info@computroniccontrols.com
Web site: www.computroniccontrols.com

FW MURPHY INSTRUMENTS (HANGZHOU) CO. LTD

77 23rd Street
Hangzhou Economic & Technological Development Area
Hangzhou, Zhejiang 310018 China
Phone: +86 571 8788 6060 Fax: +86 571 8684 8878



Printed in U.S.A.