

Installation Instructions for L971 Series Crankcase Level Switch



Please read the following information before installing. A visual inspection of this product for damage during shipping is recommended before mounting. It is your responsibility to have a qualified person install this unit and make sure it conforms to local codes.

GENERAL INFORMATION

WARNING

BEFORE BEGINNING INSTALLATION OF THIS MURPHY PRODUCT

- ✓ Disconnect all electrical power to the machine.
- ✓ Make sure the machine cannot operate during installation.
- ✓ Follow all safety warnings of the machine manufacturer.
- ✓ Read and follow all installation instructions.



Description

The Murphy L971 Series Level Switch detects low oil level in a compressor's crankcase. It is designed for Ingersoll-Rand Type 30, Type 40 and ESH compressors, yet can be adapted to fit other compressors that have an inspection plate extending below normal operating oil level. The L971 has a 1/2 NPT process connection and features an explosion-proof enclosure, durable SPDT snap-switch and rigid polyurethane foam float.

Specifications

Operating Temperature: -15 to 275°F (-26 to 135°C).

Maximum Working Pressure: 30 psi (206 kPa) [2.06 bar].

Switch Rating: 4 A @ 250 VAC.

Material

Case: *Aluminum (explosion-proof).*

Mounting Adaptor: *Brass.*

Floats:

- *Rigid polyurethane.*
- *304 stainless steel (L971-C only).*

Other Wetted Parts: *303, 304, and 316 stainless steel.*

O-Ring Seals: *Viton and Buna.*

Process Connection: 1/2 NPT.

Enclosure Rating: UL and CSA listed for Class I, Groups C & D; Class II, Groups F & G, Hazardous Locations.

Conduit Connection: 1/2 NPT.

Wire: 18 AWG (0.75 mm²).

Dimensions

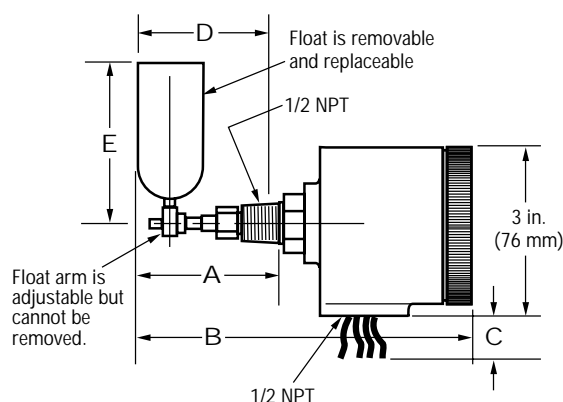

Models	Dimensions in inches* (see drawing above)				
	A	B	C	D	E
L971	2-5/8 (67)	5-7/8 (149)	30 (762)	2-1/2 (64)	2-27/32 (72)
L971-A	2-5/8 (67)	5-7/8 (149)	30 (762)	2-1/2 (64)	2-27/32 (72)
L971-B	4-13/16 (122)	8-1/16 (205)	30 (762)	4-5/8 (117)	2-27/32 (72)
L971-C	2-13/16 (71)	6-1/16 (154)	30 (762)	2-7/8 (73)	3-1/8 (79)
L971-D	3-7/8 (98)	7-1/8 (181)	30 (762)	3-3/4 (95)	2-27/32 (72)
L971-E	4-13/16 (122)	8-1/16 (205)	30 (762)	5-1/8 (130)	2-27/32 (72)
L971-F	2-5/8 (67)	5-7/8 (149)	40 (1016)	2-1/2 (64)	2-27/32 (72)
L971-G	2-5/8 (67)	5-7/8 (149)	40 (1016)	2-1/2 (64)	2-27/32 (72)

*Millimeter dimensions are shown in parenthesis ().

Warranty

A limited warranty on materials and workmanship is given with this FW Murphy product. A copy of the warranty may be viewed or printed by going to www.fwmurphy.com/support/warranty.htm

**Products covered by this literature comply with EMC Council directive 89/336/EEC regarding electromagnetic compatibility except as noted.

INSTALLATION

Compressors With Inspection Plate

1. Drain crankcase.
2. Remove crankcase inspection plate (**Figure 1**).
3. Drill and tap a 1/2 NPT female pipe thread into the inspection plate at point "A" (**Figure 2**). **CAUTION: Clean area of metal shavings.** The hole is to be a minimum of 2 in. (51 mm) below normal running oil level (**Figure 3**).

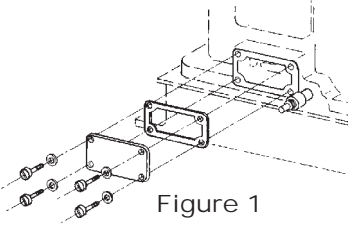

Figure 1

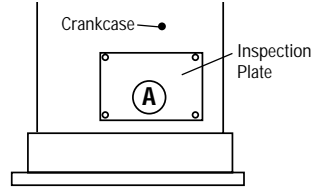

Figure 2

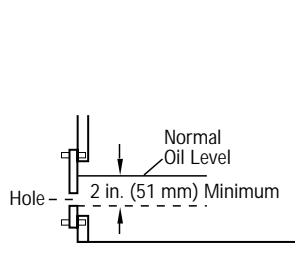

Figure 3

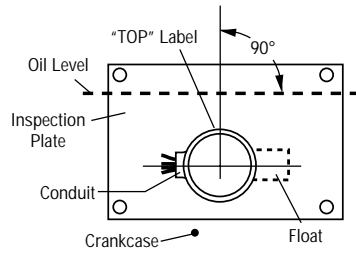

Figure 4

4. Unscrew and remove float on the L971 switch.
5. Apply pipe dope to the process connection threads.
6. Thread the L971 switch into crankcase hole until "TOP" label is up (**Figure 4**). Be sure the float moves freely and there are no obstructions.
7. If adjustment of shutdown level is required, loosen hex set screw on float attachment. Rotate float attachment to desired level. Retighten set screw.
8. Replace float and reinstall inspection plate and gasket in original position.
9. Install drain plug.
10. Wire accordingly.
11. Fill crankcase to proper level.

Compressors Without Inspection Plate

1. If installing into a thick wall crankcase, drill and tap a 1/2 NPT female pipe thread into the crankcase. **CAUTION: Clean area of metal shavings.** The hole is to be a minimum of 2 in. (51 mm) below normal running oil level (**Figure 3**).

If installing into a thin wall crankcase, drill a hole in the crankcase slightly larger than outside diameter of a 1/2 in. coupling. The hole is to be a minimum of 2 in. (51 mm) below normal running oil level (**Figure 3**). **CAUTION: Clean area of metal shavings.** Weld a half collar (1/2 NPT) into the hole.

2. Follow steps 4 thru 11 above.

FW MURPHY
P.O. Box 470248
Tulsa, Oklahoma 74147 USA
+1 918 317 4100 Fax: +1 918 317 4266
E-mail: sales@fwmurphy.com

INDUSTRIAL PANEL DIVISION
Fax: +1 918 317 4124
E-mail: ipdsales@fwmurphy.com

MURPHY POWER IGNITION
Web site: www.murphy-pi.com

www.fwmurphy.com

CONTROL SYSTEMS & SERVICES DIVISION
P.O. Box 1819
Rosenberg, Texas 77471 USA
Phone: +1 281 633 4500 Fax: +1 281 633 4588
E-mail: sales@fwmurphy.com

FRANK W. MURPHY, LTD
Church Rd Laverstock
Salisbury SP1 1OZ UK
Phone: +44 172 241 0055 Fax: +44 172 241 0088
E-mail: sales@fwmurphy.co.uk
Web site: www.fwmurphy.co.uk

COMPUTRONIC CONTROLS, LTD
41 - 43 Railway Terrace Nechells
Birmingham B7 5NG UK
Phone: +44 121 327 8500 Fax: +44 121 327 8501
E-mail: info@computroniccontrols.com
Web site: www.computroniccontrols.com

FW MURPHY INSTRUMENTS (HANGZHOU) CO. LTD
77 23rd Street
Hangzhou Economic & Technological Development Area
Hangzhou, Zhejiang 310018 China
Phone: +86 571 8788 6060 Fax: +86 571 8684 8878



Printed in U.S.A.

TYPICAL WIRING

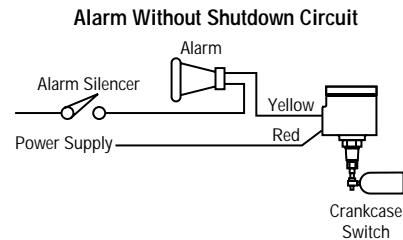
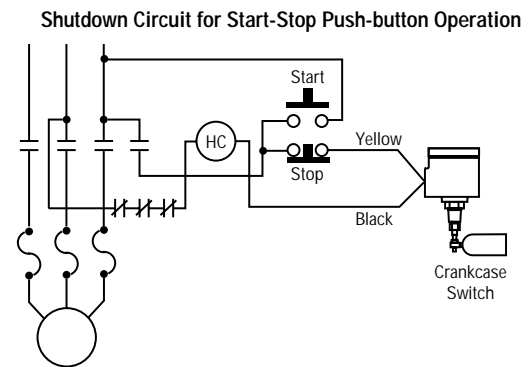
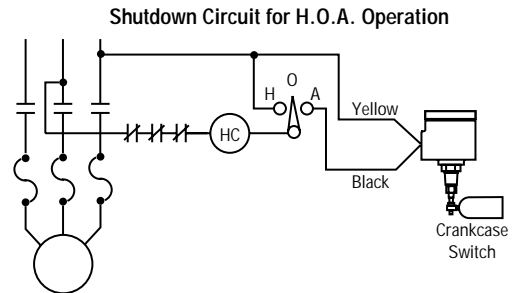
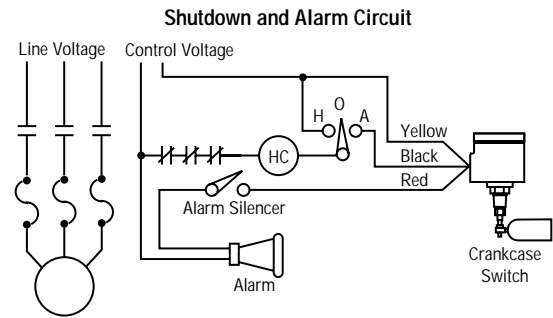

REPLACEMENT PARTS

Description	Part Number	Description	Part Number
Cover	15050443	Float	
Cover Gasket	15050369	Polyurethane	15050679
Snap-switch	00002326	Stainless Steel	15050356