

Installation and Operation Manual for DVU Series Dump Valves

Models: DVU150, DVU175, DVU2105, DVU2115 and DVU2120



Please read the following information before installing. A visual inspection of this product for damage during shipping is recommended before mounting. It is your responsibility to have a qualified person install this unit and make sure it conforms to local codes.

GENERAL INFORMATION

WARNING

BEFORE BEGINNING INSTALLATION OF THIS MURPHY PRODUCT

- ✓ Disconnect all electrical power to the machine.
- ✓ Make sure the machine cannot operate during installation.
- ✓ Follow all safety warnings of the machine manufacturer.
- ✓ Read and follow all installation instructions.

Description

The DVU Series models are pneumatically controlled dump valves. The valves open and close automatically by pneumatic control from a Murphy L1200NDVOR or similar level controller and dump valve operator. Diaphragm actuated, the DVU series dump valves operate at 30–70 psi (207–483 kPa) [2.07–4.83 bar] and up to 2000 psi (13.8 MPa) [138 bar] vessel pressure (depending on the model).

A key benefit of this design is a hex union that provides the ability to replace the seat without removing the valve from piping.

Fig. 1 Control Pressure vs. Working Pressure

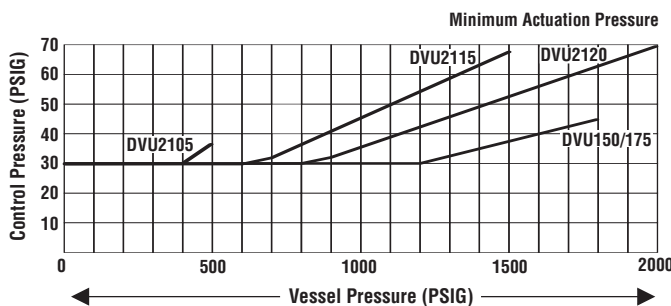

Model	Inlet	Outlet	Trim Size
DVU2120	2 NPT	1 NPT	0.436 in. (11 mm)
DVU2115	2 NPT	1 NPT	0.576 in. (15 mm)
DVU2105	2 NPT	1 NPT	0.859 in. (22 mm)
DVU175	1 NPT	3/4 NPT	0.359 in. (9 mm)
DVU150	1 NPT	1/2 NPT	0.359 in. (9 mm)

Fig. 2 Dimensions (all models)

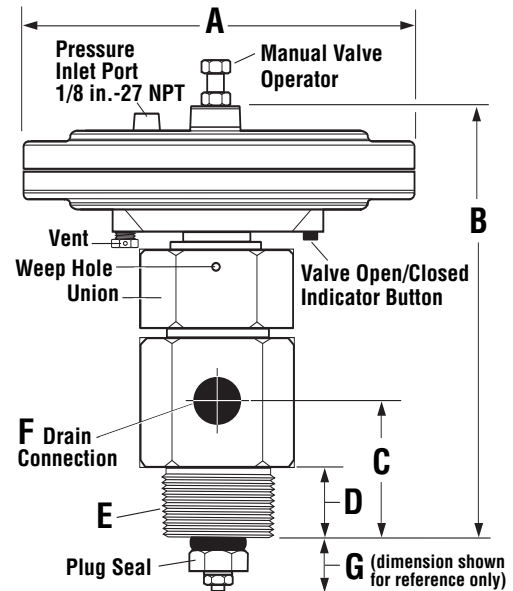

Model	A	B	C	D	E	F	G
DVU2120	7.50 (191)	8.0 (203)	2.75 (70)	1.0 (25)	2-11.5 NPT	1-11.5 NPT	1.03
DVU2115	7.50 (191)	8.0 (203)	2.75 (70)	1.0 (25)	2-11.5 NPT	1-11.5 NPT	1.03
DVU2105	7.50 (191)	8.0 (203)	2.75 (70)	1.0 (25)	2-11.5 NPT	1-11.5 NPT	1.03
DVU175	7.50 (191)	6.75 (171)	2.06 (52)	1.0 (25)	1-11.5 NPT	3/4"-14 NPT	1.03
DVU150	7.50 (191)	6.75 (171)	2.06 (52)	1.0 (25)	1-11.5 NPT	1/2"-14 NPT	1.03

NOTE: Dimensions are in inches and (millimeters)

Specifications

Operating Temperature: -30 to 250°F (-34.4 to +121°C)

Valve Operating Pressure: Refer to chart, Fig 1.

Maximum Process Pressure:

DVU2120: 2000 psi (13.8 MPa) [138 bar].

DVU2115: 1500 psi (10.3 MPa) [103 bar].

DVU2105: 500 psi (3.44 MPa) [34 bar].

DVU150 and DVU175: 1800 psi (12.4 MPa) [124 bar].

Flow Characteristics: See chart, page 4 (DVU150/175 models only).

Body Material: Electroless Nickel Plated 12L14 Carbon Steel

Internal Wetted Parts: Plug Seal: 90 Durometer Urethane.

Other: 303 stainless steel; Electroless Nickel Plated 12L14 Carbon Steel

Shipping Weights: DVU150 and DVU175: 9 lbs. (4 kg.).

Shipping Weights: DVU2105, DVU2115 and DVU2120: 14 lbs. (6.4 kg.).

Shipping Dimensions: 7-1/2 x 7-1/2 x 10-3/4 in. (191 x 191 x 274 mm.).

TYPICAL INSTALLATION ON GAS COMPRESSORS

Fig. 3
Scrubber/Separators

Basic Operation

As condensate rises in the scrubber, the float on the L1200NDVOR rises and trips its pneumatic valve. The valve opens allowing pressure to enter the dump valve pilot chamber. Once the pressure enters the pilot chamber it forces the diaphragm and valve stem forward thus opening the valve seat (valve open/closed indicator button pops out) and releasing condensate through the valve stem and out the drain. As the condensate level drops, the L1200NDVOR pneumatic valve closes to shut off the pressure to the dump valve causing it to close.

If for any reason the condensate continues to rise beyond normal dump levels, model L1200 operates the alarm and/or shuts down the equipment.

The L1200NDVOR Filter/Regulator and the MURPHYGAGE® help keep the control pressure clean and dry. They also allow the operator to adjust pressure to recommended levels.

NOTE: Always use clean, dry, instrument quality gas.

The Murphy Gas Compressor Scrubber Level System (SLS)

The system provides for liquid control in gas scrubber applications, by dumping liquids to drain and protecting compressors with a high liquid level switch. Wetted metal parts are made to survive constant use in corrosive environments.

See Bulletin: SLS-04005B for more details.

Filter/Regulator & MURPHYGAGE®

"Instrument Quality Air/Gas Supply"

Pneumatic Level Control

Float actuated level snap-acting switch controls pneumatic pressure to open and close dump valve.

L1200NDVOR: Dump Valve Operator, pressure regulator, and pressure indicating MURPHYGAGE.®

High Level Shutdown Switch

Stainless steel float actuated level switches to alarm and/or shutdown the equipment.

L1200: 2" NPT pipe connection; Rated 2000 psi (13.7MPa) [137bar]; Class I, Division 1. SPDT snap-switch standard. DPDT Optional.

All Stainless Steel available.

Control Panel

Pneumatic Dump Valves

See DVU-01069B for more details.

Two piece union design with manual valve operator allows soft plug and hard seat to be replaced without disassembling outlet piping or scrubber pipe connection. Diaphragm actuated valves operate on 30-70 psi (207-483 kPa; 2-5 bar).

DUMP VALVE INSTALLATION

DVU Series Installation



CAUTION: ALWAYS USE "NON-SPARKING TOOLS" WHEN GAS IS KNOWN TO BE PRESENT.

The following describes the "Direct Mounting" method to the tank wall.

1. Install the valve so the drain connection is on the bottom. Use pipe thread sealant on all the connections.
2. Be sure the unit is screwed tight and does not leak.
3. Install the piping for the pneumatic input signal into the 1/8 NPT threaded connection of the pressure inlet port (on top of the diaphragm housing of the DVU).
6. Install a union between the DVU drain connection and the condensate out line. Use pipe thread sealant on all the connections.

Fig. 4
Typical Dump Valve Installation

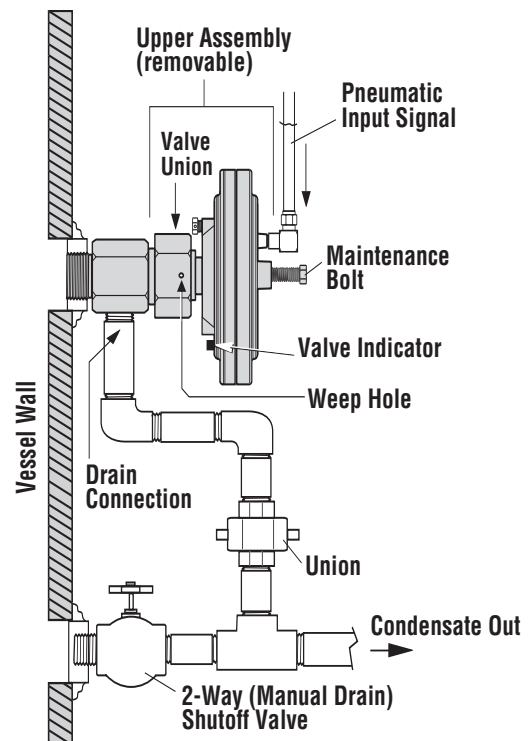

REPAIR PROCEDURE



CAUTION: THE INSTALLATION AND REPAIR PROCEDURES SHOULD ONLY BE PERFORMED BY TRAINED, QUALIFIED, AND EXPERIENCED PERSONNEL. THE TRAINING, QUALIFICATION AND EXPERIENCE REQUIRED IS FOR WORK AROUND PRESSURE VESSELS, NATURAL GAS, POSSIBLY SOUR GAS, OR ANY SUBSTANCE TO BE FOUND IN THE VESSEL. EXTREME CARE MUST BE TAKEN TO INSURE ANY RESIDUAL OR FULL PRESSURE IS RELIEVED FROM ALL PARTS OF THE SYSTEM TO BE SERVICED.

Suggested Tools (Sizes listed are wrench openings. Adjustable crescent wrenches, socket and/or end wrench, pipe wrenches, flat edge screwdriver with 1/4" blade width, can also be used.)

Model	Valve Body	Union Nut	Plug Seal Hex	Stem Nut
DVU2120	3"	3"	7/8"	1/2"
DVU2115	3"	3"	1"	1/2"
DVU2105	3"	3"	1-1/4"	1/2"
DVU150/DVU175	2-1/4"	2-1/4"	3/4"	3/8"

Replacing the Plug and Seat

1. Close the pressure block valves (suction & discharge valves) on the inlet and outlet of the skid. Lock them closed if possible.
2. Open the blowdown valve to remove pressure from the unit. Lock the blowdown valve open if possible.
3. After taking all possible precautions to insure there is no pressure in the vessel. (If the condensate line is pressurized, it must also be blocked and locked.) Open the manual drain valve so it bleeds into the vessel so it can also be bled down. Disconnect the pneumatic input signal connection after insuring it also has been de-pressurized.
4. Using a back-up wrench on the valve body, with a quick "breaking" action loosen the union nut on the valve. There is a "weep" hole in the nut. If at any time while loosening and taking off the nut pressure is escaping through the "weep" hole, immediately stop loosening the nut. Retighten the nut and check the preceding procedures to ensure the pressure is bled off the vessel. Never remove the assembly if pressure is coming through the weep hole. **See Figure 4 on page 2.**
5. With the upper assembly removed from the vessel the plug and/or seat can be replaced. Loosen the 9/16" jam nut on the maintenance bolt on top of the diaphragm cover. Spin the nut up against the head of the bolt. Tighten the bolt to extend the shaft and plug. **DO NOT OVERTIGHTEN.**

Fig. 5

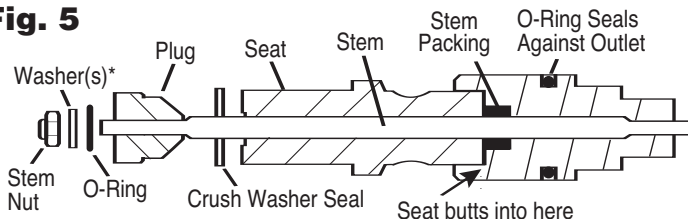

*Number of washers varies depending on the model from 1 to 3.

Fig. 6

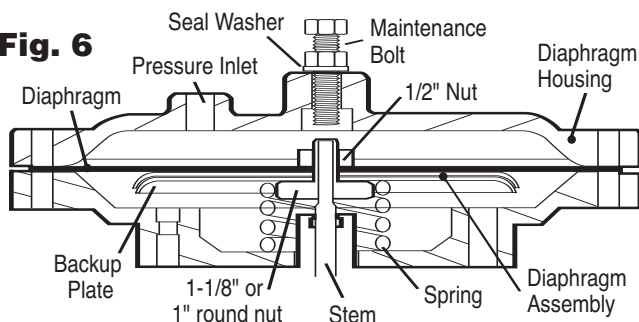

6. Using a back-up wrench on the plug, remove the stem nut on the shaft under the plug. Once the stem nut is broken loose, the 9/16" head maintenance bolt and top assembly will keep the stem from turning. The plug turns freely on the stem once loose. The plug and seat can now be removed. All soft seals should be replaced. Refer to kit part numbers under service parts on page 4.

Replacing the Diaphragm

- 6A. If the diaphragm is to be replaced, all preceding steps have to be done. Additionally, do the following:
 - 6B. Loosen the 9/16" head maintenance bolt, allowing the diaphragm spring to relax, and the stem to retract. Make alignment marks on the top and bottom halves of the diaphragm assembly for alignment during re-assembly.
 - 6C. Remove the 8, 7/16" bolts/nuts holding the diaphragm housing together.
 - 6D. Using a straight edge screwdriver, gently separate the 2 halves of the diaphragm housing, and remove the top, or outside portion.
 - 6E. Lift the diaphragm and support plates far enough for the 1-1/8" hex or 1" round nut on the bottom of the diaphragm assembly to be accessible to a wrench and not have the spring interfere. If it is desired to replace the packing, pull the stem all the way out. The packing can be easily removed using a small screwdriver to pry the packing out. The new packing can be simply pressed in, making sure the orientation of the packing installed is the same as the orientation of the packing removed. The packing is wider toward the plug end. You will have to use the seat to hold the packing in place when re-inserting the stem.
 - 6F. With the 1-1/8" hex or 1" round nut held by a wrench, use a wrench to loosen and remove the 1/2" nut on top of the diaphragm. The diaphragm can now be removed and replaced.
 - 6G. With the new diaphragm in place and the 1/2" nut tightened, place the assembly, diaphragm down on a clean, smooth sturdy surface.
 - 6H. Have the seat, plug, washers and stem nut handy (if any of these parts are to be replaced, use the old parts for this procedure). Press down evenly and smoothly on the bottom of the diaphragm assembly to cause stem to come up. Place the seat and plug in place. Then push the bottom of the diaphragm assembly down far enough to install the washers and stem nut on the stem. Tighten the stem nut enough to hold against the diaphragm spring.
 - 6J. Align the diaphragm holes to the bolt holes (bottom half of the housing). Install the upper diaphragm housing using the alignment marks from step 6B. Install the 8, 7/16" bolts and nuts. Tighten the bolts evenly going from one bolt then 180° around to the next bolt, then either 120° or 240° around to the next bolt and so forth until all 8 bolts are evenly tight.
 - 6K. Using the 9/16" head maintenance bolt, tighten, pushing the stem out until the 9/16" bolt stops – **DO NOT OVERTIGHTEN.**
 - 6L. Remove the stem nut holding the plug. (If old parts were used, prepare to install the new parts now.)
7. Install the seat and plug. Place the O-ring on the stem, followed by the washer and stem nut.
 8. Tighten the stem nut. Loosen the 9/16" head maintenance bolt by at least one turn past the point where it is no longer in contact with the stem. Tighten the 9/16" jam nut holding the 9/16" head maintenance bolt.
 9. Replace the crush washer and the O-ring hidden by the union nut. **NOTE: If pressure or fluid comes out the weep hole of the union nut, either the O-ring under the union nut is leaking, or the packing could be leaking through the internal weep hole above that O-ring.**
 10. The assembly is ready to be re-installed. Check for relative position of the pneumatic input signal connections before tightening the union nut.

PRESSURE VS. FLOW CHART

Fig. 7 Pressure vs. Flow for DVU150 and DVU175 models only

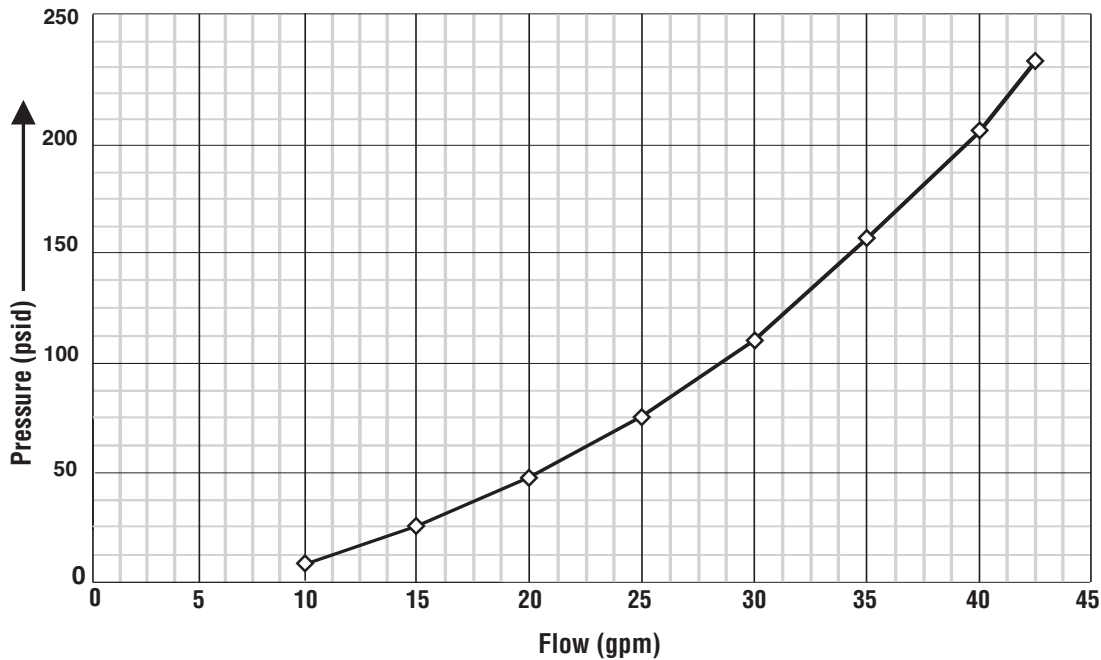

SERVICE PARTS

Part No.	Description
DVU2120	
55-00-0237	Seal Kit (includes plug)
55-00-0236	Diaphragm Kit
DVU2115	
55-00-0241	Seal Kit (includes plug)
55-00-0240	Diaphragm Kit
DVU2105	
55-00-0245	Seal Kit (includes plug)
55-00-0244	Diaphragm Kit
DVU175	
55-00-0230	Seal Kit (includes plug)
55-00-0231	Diaphragm Kit
DVU150	
55-00-0230	Seal Kit (includes plug)
55-00-0231	Diaphragm Kit

Typical Seal Kit includes: Nut, Washer (1 to 3), "O" Ring, Plug and Seal, Seat, Crush Washer.

Typical Diaphragm Repair Kit includes:

Diaphragm; Diaphragm Washer (upper), Diaphragm Nut, Diaphragm Plate (1 or 2 pcs.), Packing, "O" Ring, Stem, Seal Washer for Maintenance Bolt.

The DVU Series Valve is included in the following Scrubber Levels Systems.

(Includes LS200, LS200NDVOR, and DVU valve)

SLS2120: Includes DVU2120 valve

SLS2115: Includes DVU2115 valve

SLS2105: Includes DVU2105 valve

SLS175: Includes DVU175 valve

SLS150: Includes DVU150 valve

-LR: Less Regulator option

Warranty

A limited warranty on materials and workmanship is given with this FW Murphy product. A copy of the warranty may be viewed or printed by going to www.fwmurphy.com/support/warranty.htm

FW MURPHY
P.O. Box 470248
Tulsa, Oklahoma 74147 USA
+1 918 317 4100 Fax: +1 918 317 4266
E-mail: sales@fwmurphy.com

INDUSTRIAL PANEL DIVISION
Fax: +1 918 317 4124
E-mail: ipdsales@fwmurphy.com

MURPHY POWER IGNITION
Web site: www.murphy-pi.com

CONTROL SYSTEMS & SERVICES DIVISION
P.O. Box 1819
Rosenberg, Texas 77471 USA
Phone: +1 281 633 4500 Fax: +1 281 633 4588
E-mail: sales@fwmurphy.com

FRANK W. MURPHY, LTD
Church Rd Laverstock
Salisbury SP1 1QZ UK
Phone: +44 172 241 0055 Fax: +44 172 241 0088
E-mail: sales@fwmurphy.co.uk
Web site: www.fwmurphy.co.uk

COMPUTRONIC CONTROLS, LTD
41 - 43 Railway Terrace
Nechells, Birmingham B7 5NG UK
Phone: +44 121 327 8500 Fax: +44 121 327 8501
E-mail: sales@computroniccontrols.com
Web site: www.computroniccontrols.com

www.fwmurphy.com

Installation 00-02-0483 page 4 of 4

FW MURPHY INSTRUMENTS (HANGZHOU) CO. LTD
77 23rd Street
Hangzhou Economic & Technological Development Area
Hangzhou, Zhejiang 310018 China
Phone: +86 571 8788 6060 Fax: +86 571 8684 8878

FW MURPHY INTERNATIONAL TRADING (SHANGHAI) CO., LTD.
Suite 1704, Tower B, City Center of Shanghai; 100 Zunyi Road
Shanghai, 200051 China
Phone: +86 21 6237 2082 Fax: +86 21 6237 2083
Web site: mhong@fwmurphy.com



Printed in U.S.A.