

Swichgauge® Kits for Engines

WD-8198B
Revised 03-06
Catalog Section 30
(00-02-0088)

WD100 Series



- **Universal Mounting Panel**
- **Guard against low oil pressure or high running temperature**
- **For farm or construction equipment**

Description

The WD100 Series Swichgauge kits provide engine monitoring that shuts down farm, construction, or other engine powered equipment, when dangerous pressures or temperatures occur. The control center for each of these kits is the compact and adjustable, Universal Mounting Panel. This panel holds two Swichgauge(s) and a Tattletale® magnetic switch, and shut down device where appropriate.

Specifications

- Murphy Swichgauge products are two-instruments-in-one: (1) an accurate indicating gauge with (2) a built-in, adjustable, limit switch.
- 518PH Tattletale magnetic switch is designed to shut down engines; operates as a circuit breaker to interrupt the ignition circuit to a distributor or to close a solenoid fuel valve on diesels.
- Temperature capillary tubes are 6 ft. (1.8 m) standard, but can be ordered in any length.
- Standard Swichgauge ranges*:
Pressure: 0-100 psi (0-689 kPa) [0-6.89 bar]
Temperature: 100-250°F (37-121°C)

*Other ranges are available on request.

WD100 Series Kits

Depending upon the kit selected, the following components are supplied:

- A Universal Mounting Panel which consists of:
- 20P, oil pressure Swichgauge instrument
 - 20T, temperature Swichgauge instrument with 6 ft. (1.8 m) capillary, or 20TH, temperature Swichgauge instrument for WD175 kit.
 - 518PH Tattletale magnetic switch
- B Bracket mounting bolts, washers and nuts.
- C CKV2336, fuel reverse flow/check valve.
- D PRV50, fuel pressure relief valve
- E SV-Series, fuel shut-off solenoid valve (1/4 NPT X 1/4 NPT)
Specify 12VDC or 24VDC.

Kit Combinations

These kits are available for virtually any engine application, any engine type, or can be custom ordered to meet a specific use.

Kit WD100 includes: A, and B

Suitable for use on distributor ignition engines or on diesels having a shutdown solenoid in the fuel pump.

Shipping Weight: 4.75 lbs (2.2 kg)

Shipping Dimensions: 9-3/4 in. x 9-1/4 in. x 5-3/4 in. (248 mm x 235 mm x 146 mm)

Kit WD150 includes: A, B, C, and E

Suitable for most liquid cooled diesel engines.

Shipping Weight: 6.15 lbs (2.8 kgs.)

Shipping Dimensions: 9-3/4 in. x 9-1/4 in. x 5-3/4 in. (248 mm x 235 mm x 146 mm)

Kit WD175 includes: A, B, C, and E

Suitable for air cooled diesel engines; 10 mm 1.5 adaptor and special head temperature bulb. Includes SV-Series fuel valve.

Shipping Weight: 6.15 lbs (2.8 kgs.)

Shipping Dimensions: 9-3/4 in. x 9-1/4 in. x 5-3/4 in. (248 mm x 235 mm x 146 mm)

Kit WD185 includes: A, B, C, D, and E

Suitable for engines with gear driven transfer pump. (SV-Series is not required on engines with built-in shutdown in the injector pump.)

Shipping Weight: 6.20 lbs (2.8 kgs.)

Shipping Dimensions: 9-3/4 in. x 9-1/4 in. x 5-3/4 in. (248 mm x 235 mm x 146 mm)

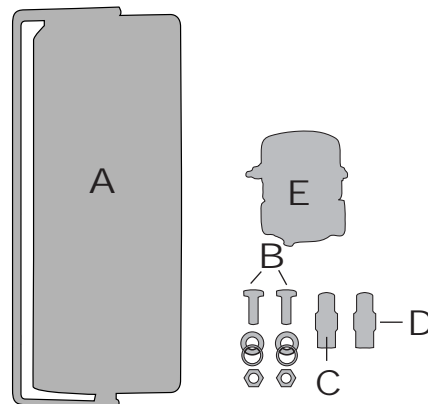

—Especially designed for adaption to a wide variety of engines.

Typical Wiring to Diesel Engine

Special Notes:

- Murphy Pressure Relief Valve; model PRV50 is factory set to start opening at 25 psi (172 kPa) [1.72 bar]. This is done to protect the fuel filter canister from bursting due to high pressure.
- Install the Murphy Check Relief Valve, model CKV2336, **as close as possible to the injection pump**. When the CKV2336 is installed

- properly it should prevent the injection pump from siphoning fuel thus not allowing continued operation after the SV valve closes.
- Install the SV-Series fuel valve as close as possible to the injection pump inlet port.
- **All fittings must be air tight.**

CAUTION: Certain dangers to human safety and to equipment may occur if some equipment is stopped without pre-warning. In these cases, it is recommended that monitored functions be limited to alarm-only or to alarm before shutdown.

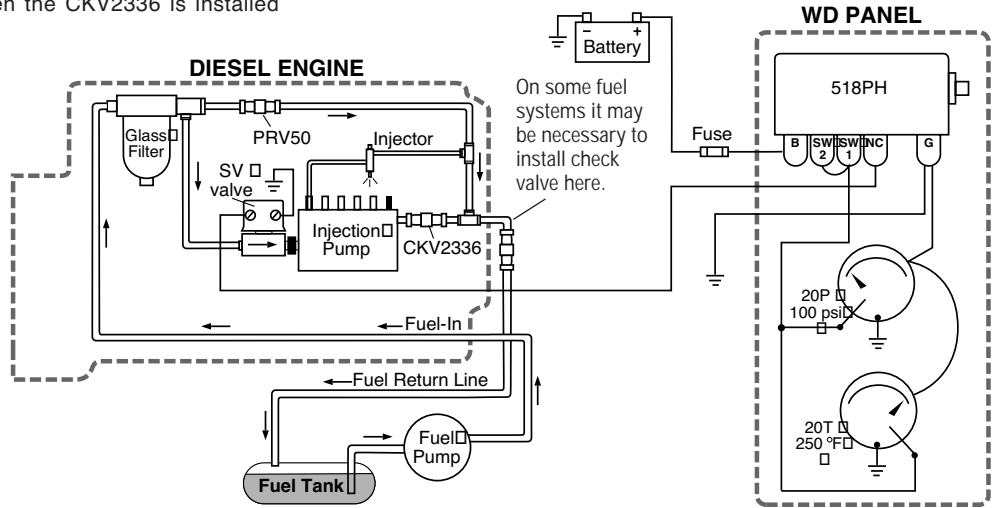

Dimensions

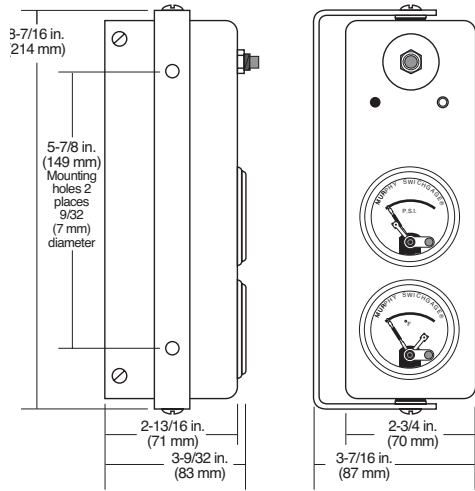

Rotating/Tilting Panel

It is the ability of this panel to mount in many different positions (Switchgag instruments can be rotated, the panel tilted) that allows for instrument visibility without a difficult installation or interference with other engine equipment.

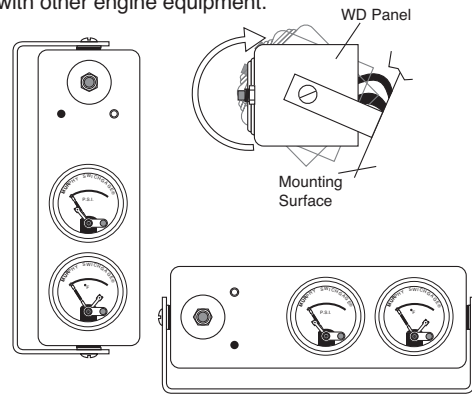

How to Order

To determine the kit that will suit your application, refer to the **Kit Combinations** on the reverse side. When you have decided on a kit, the model number and voltage must be specified when ordering. Example: **WD100, 12 Volt**

Approximate Shipping Weights and Dimensions for each kit are specified on the reverse side of this bulletin, under **Kit Combinations**. Order oil line assembly separately.

Warranty

A limited warranty on materials and workmanship is given with this FW Murphy product. A copy of the warranty may be viewed or printed by going to www.fwmurphy.com/support/warranty.htm



www.fwmurphy.com

918.317.4100 Email: sales@fwmurphy.com

In order to consistently bring you the highest quality, full featured products, we reserve the right to change our specifications and designs at any time. MURPHY, the Murphy logo, and Switchgag® are registered and/or common law trademarks of Murphy Industries, Inc. This document, including textual matter and illustrations, is copyright protected by Murphy Industries, Inc., with all rights reserved. (c) 2006 Murphy Industries, Inc.