

Industrial Catalytic Converters

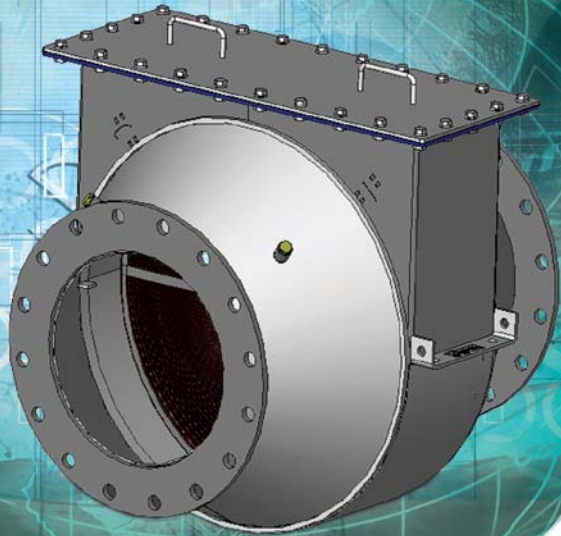
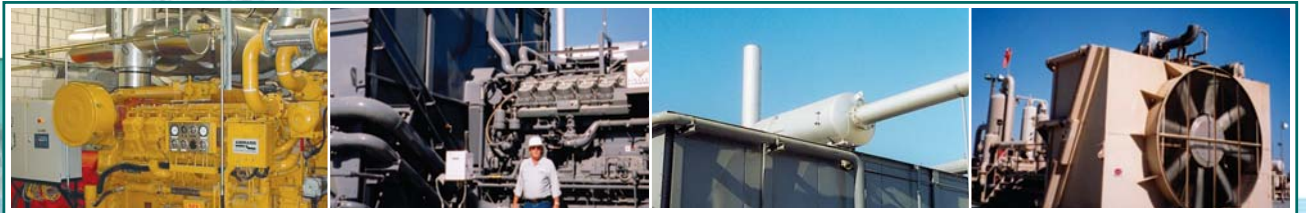

QUICK-LID™

Power Generation Co-Generation Gas Compression Fluid Pumping

QUICK-LID™

A New Generation of Catalyst Housing Technology

With DCL's latest generation of the QUICK-LID™ catalytic converter, operation and maintenance is quicker and easier than ever, lowering your service hours and cost of ownership. The new generation QUICK-LID™ effectively reduce emissions from rich-burn natural gas, lean-burn natural gas and diesel stationary engines used in gas compression, power generation, and other industrial applications. As the industry standard for reliable, long life operation, every QUICK-LID™ is backed with a performance guarantee for emissions, providing you worry free compliance for even the most stringent environmental operating permit.

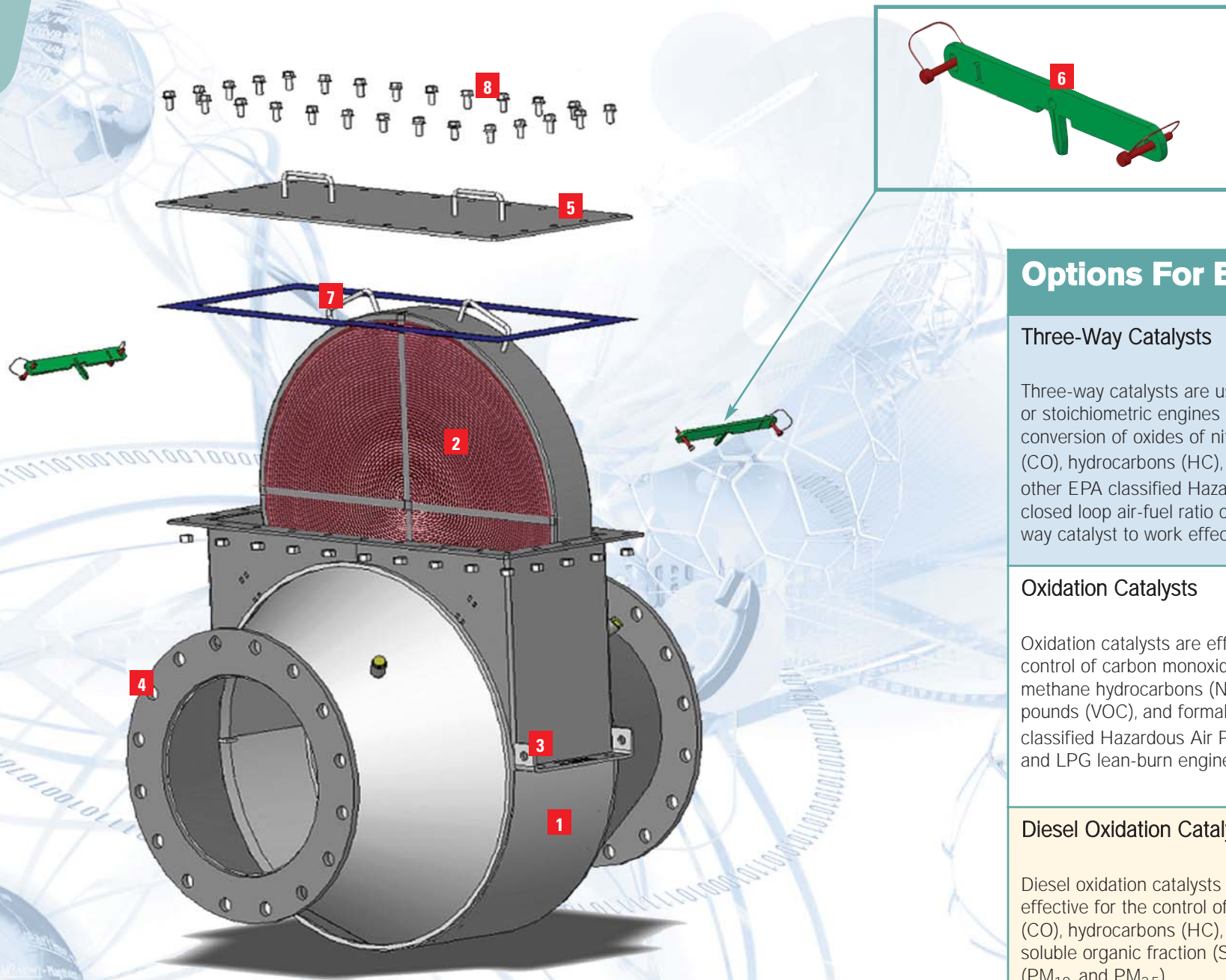

1 304L Stainless Steel Housing

Designed for long life in the most extreme duty applications, rated for 1.5 atmospheres pressure, and space for additional catalyst element.

2 Advanced Design Catalyst Element

Metal foil substrate with rigid supports and patented C-channel provides long life under the most extreme conditions. Also available in a variety of cell densities to optimize back pressure and performance.

3 Mounting Brackets

Accommodates both horizontal and vertical mounting.

4 Connecting Flanges

Available in a variety of connection types, including ANSI and DIN bolt pattern flanges.

5 Cover Plate

Allows easy access for servicing of catalyst element.

6 Retaining Bars

Holds catalyst element securely in place while allowing quick removal of catalyst element in seconds.

7 Catalyst Element Handles

Ideal for easy installation and maintenance.

8 Flanged Lock Bolts and Nuts

Eliminates the need for lock washers.

Options For Every Engine Type

Three-Way Catalysts

Three-way catalysts are used in rich-burn or stoichiometric engines for simultaneous conversion of oxides of nitrogen (NO_x), carbon monoxide (CO), hydrocarbons (HC), and formaldehyde (CH₂O) and other EPA classified Hazardous Air Pollutants (HAPs). A closed loop air-fuel ratio controller is required for the three-way catalyst to work effectively.

Rich-Burn



Oxidation Catalysts

Oxidation catalysts are effective for the control of carbon monoxide (CO), non-methane hydrocarbons (NMHC), volatile organic compounds (VOC), and formaldehyde (CH₂O) and other EPA classified Hazardous Air Pollutants (HAPs) from natural gas and LPG lean-burn engines.

Lean-Burn



Diesel Oxidation Catalysts

Diesel oxidation catalysts (DOCs) are effective for the control of carbon monoxide (CO), hydrocarbons (HC), odor causing compounds, and the soluble organic fraction (SOF) of particulate matter (PM₁₀ and PM_{2.5}).

Diesel

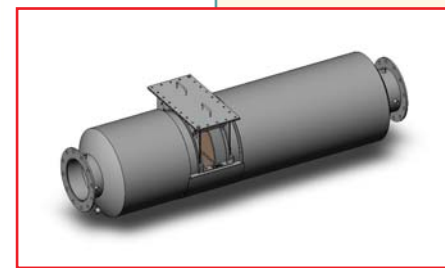

The new generation QUICK-LID™ is also available as a catalytic silencer combination for industrial, critical and hospital grade silencing.

DCL International Inc. – Preserving and Improving the Quality of the Air We Breathe

DCL International Inc. is a global leader in the engineering, manufacturing and supporting of advanced emissions control technology for stationary and mobile industrial engines. Our products – which include oxidation and three-way catalysts, silencers, particulate filters, SCR systems and accessories – are used worldwide in the material handling, construction, mining, gas compression and power generation markets.

DCL's dedicated industrial focus is unique in the emissions control industry. To meet the specialized needs of the industrial market, we adopt an integrated approach, bringing together product development, design, manufacturing and testing all under one roof. This single-source capability enables us to provide better engineered emissions solutions that deliver outstanding performance, longer life and lower cost of ownership. Our superior product quality has made DCL the choice of customers around the world.

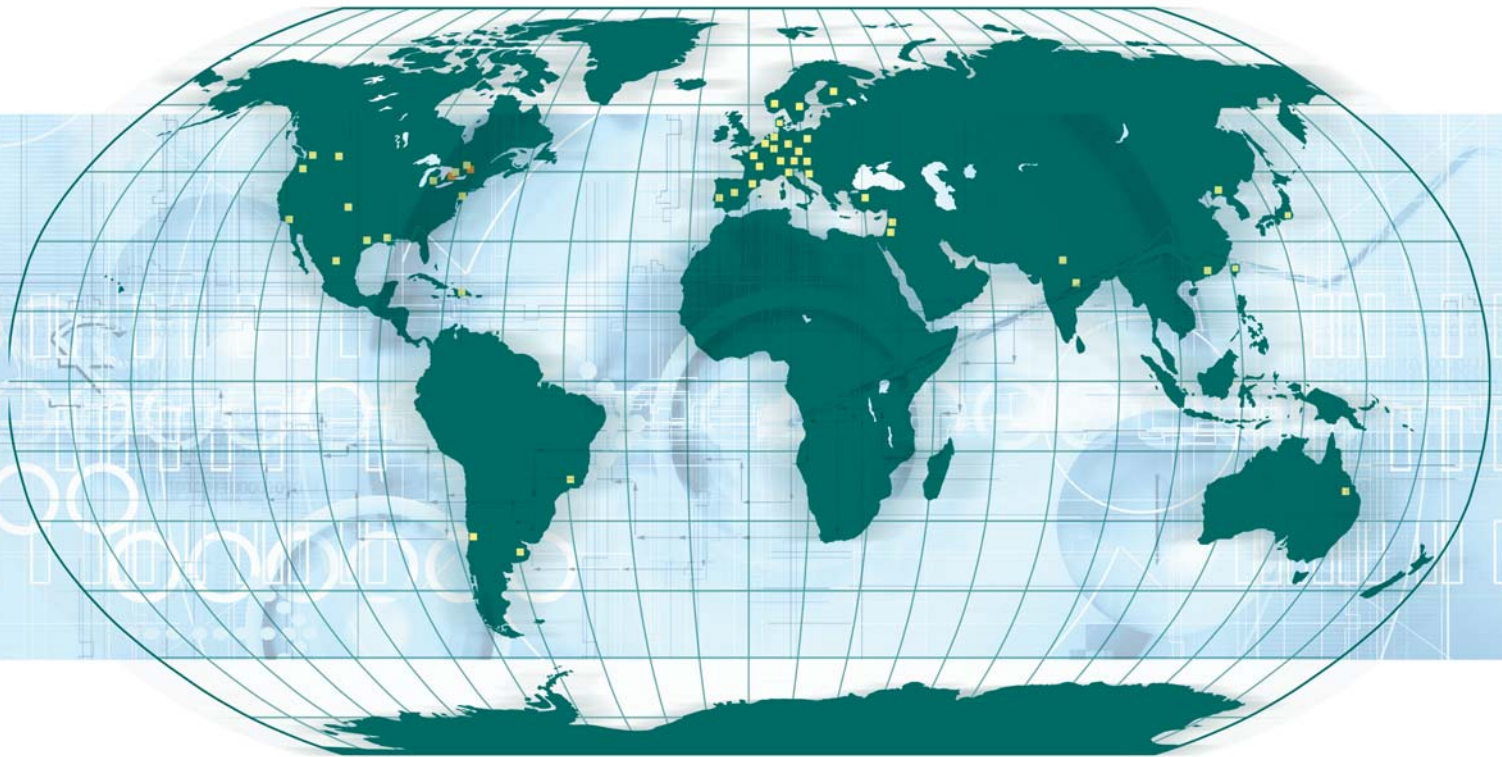
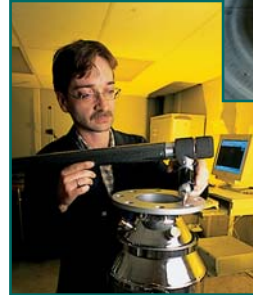

■ *Manufacturing Facilities*

■ *Representatives*



DCL International Inc.

DCL International Inc.
Corporate Headquarters
P.O. Box 90
Concord, Ontario
L4K 1B2, Canada

1-800-872-1968

Phone: (905) 660-6450
Fax: (905) 660-6435
e-mail: info@dcl-inc.com
web: www.dcl-inc.com

ISO 9001:2000 Registered